

INSTRUCTION MANUAL

PRO
COBRA
SRX8E

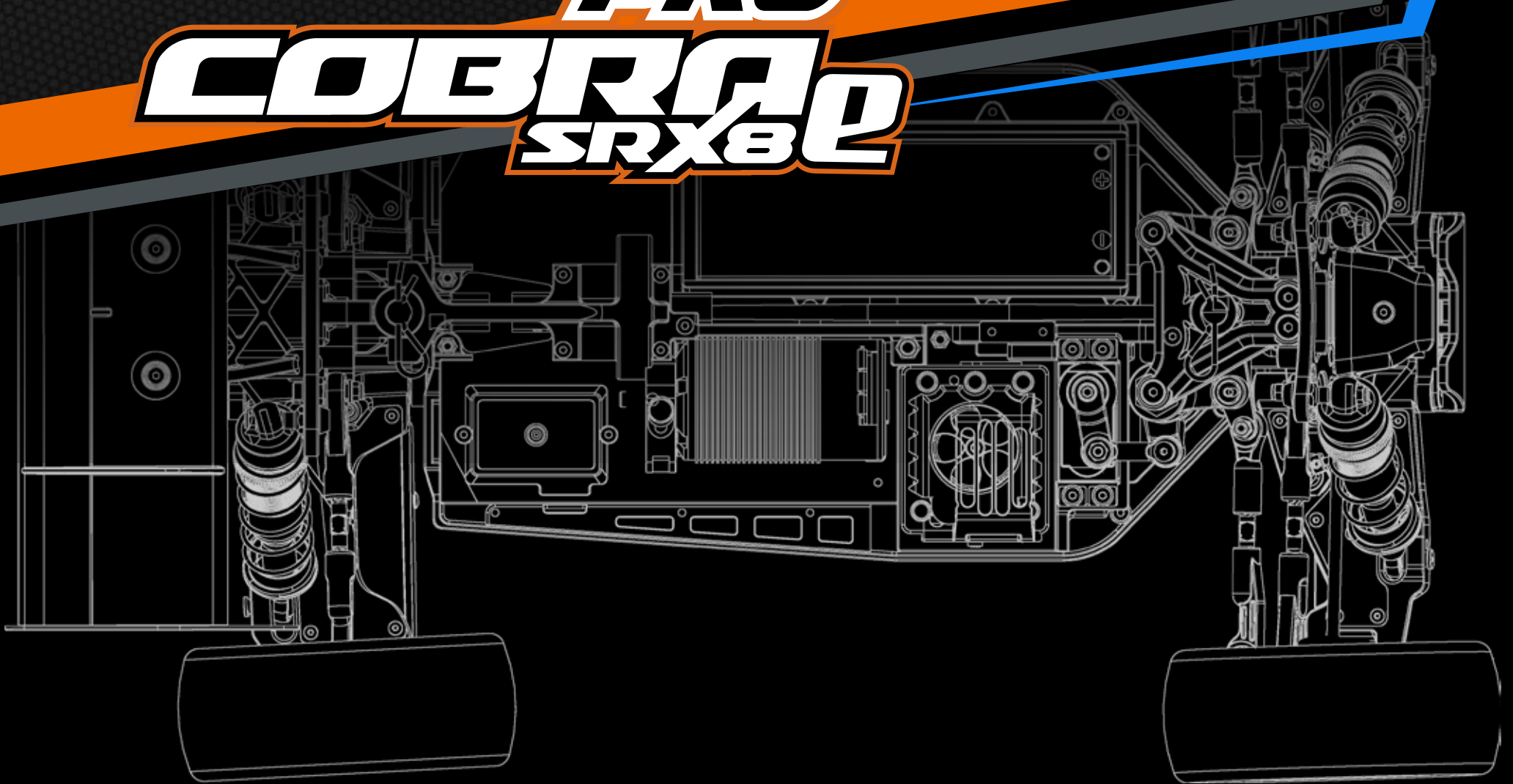

SERPENT

INTRODUCTION

Thank you very much for selecting this Serpent rc car and thus become a member of the ever growing worldwide Serpent racing family. Serpent started in 1980 and has been growing its product-line and fan-base ever since.

The Serpent Cobra SRX8-E PRO is a state of the art 1/8 scale 4wd buggy which will give you the true Serpent racing experience. The assembly manual will guide you through all the steps to complete the car, so you can hit the track with a good base-set-up soonest. The Serpent design department succeeded to create a superbly performing car combined with easy of assembly and maintenance. The high quality standards of all parts and hardware will make racing your Serpent car a very rewarding activity !

Through our team, website and social media we will keep you up-to-date on all developments of the Serpent cars. We hope to meet you on the track and through our various media! Enjoy the drive !

Team Serpent
Multiple World Champions

INSTRUCTIONS

Serpent's long tradition of excellence extends to the instruction manuals, and this instruction manual is no exception. The easy-to-follow layout is richly illustrated with 3D-rendered full-color images to make your building experience quick and easy. Following the instructions will result in a well-built, high-performance race-car that will soon be able to unleash its full potential at the racetrack. The kit includes bags, with bag numbers, which refer to the same step in the manual. Open only the indicated bag(s) per step and finish that part of the assembly. Remaining parts will be needed later on in the assembly process.

PLASTIC PARTS

The Serpent moulded parts are very durable and hard. When assembling longer screws in new composite parts, make sure to use new hex bits in your (power) tools. Pre-threading also helps to avoid screw damage.

SETUP

In certain assembly steps you need to make basic adjustments, which will give you a good initial setup for your Serpent Cobra SRX8-E PRO. Fine-tuning the initial setup is an essential part of building a high-performance racecar like your Serpent Cobra SRX8-E PRO.

EXPLODED VIEWS AND PARTS LIST

The exploded views and parts lists for the Serpent Cobra SRX8-E PRO are presented in the Reference Guide section in the back of this manual. The exploded views show all the parts of a particular assembly step along with the Serpent part number and hotlink to the Serpent website. Part numbers in orange indicates that this part is an optional. Optionals part names and numbers are showed below.

CUSTOMER SERVICE

Serpent has made a strong effort to make this manual as complete and clear as possible. Additional info may be published in our website: www.serpent.com or you may ask your dealer or the Serpent distributor for advice, or email Serpent direct: info@serpent.com. The Serpent Facebook, Twitter and Youtube pages give additional means of support and communications.

SAFETY

Read and take note of the 'Read this First section' before proceeding to assemble the car-kit. This car-kit is intended for persons aged 16 or older.

READ THIS FIRST!

- This is a highly technical hobby product, intended to be used in a safe racing environment. This car is capable of speeds in excess of 80 km/h or 50mph. Please follow these guidelines when building and operating this model.
- Parental guidance is required when the builder/user of this car is under 16.
- Follow the building instructions. If in doubt, contact your dealer or importer.
- Be sure to use the proper tools when assembling the car. Always exercise caution when using electric tools, knives and other sharp objects.
- Be careful when using liquids like lubrication oil, fuel or glue. Do not swallow.
- Follow the manufacturer's instruction in case you experience irritation after using the product.
- Be careful when operating the car. Stay away from any rotating parts such as wheels, gears and transmission. Stay away from motor, engine and exhaust pipe system or speedo during and immediately after use, as these parts may be very hot. We advise to use protective hand gloves.
- Only operate this car in a safe environment, like a special racing track or a closed parking lot. Avoid using this car on public roads, crowded places or near infants.
- Before operating this car, always check the mechanical status of the car. Also check that the transmitter and receiver frequencies correspond and are not used by any other racer at the same time. Check that the batteries of the transmitter and receiver- are fully charged.
- After use, always check all the mechanics of the car. We advise to clean the car immediately after use, and inspect the parts for wear or fractures. Replace when necessary. Do not use water, methanol, thinner or other solvents to clean the car.
- After your session, disconnect the main battery from the speed control.
- Store the car in a dry and heated place to avoid corrosion of metal parts.
- Avoid using this car in wet conditions as the water will cause corrosion on the metal parts and bearings and these parts will cease to function properly. If driven in the wet, ensure that all the electric equipment is waterproofed and after use, that all moving parts are dried immediately.

CONTENTS

• CENTER DIFF ASSEMBLY.....	4
• FR/RR DIFF ASSEMBLY.....	6
• REAR ASSEMBLY.....	8
• CENTRAL ASSEMBLY.....	22
• STEERING ASSEMBLY.....	24
• RADIO ASSEMBLY.....	27
• SHOCK ASSEMBLY.....	31
• FINAL ASSEMBLY.....	34
• CLUTCH ASSEMBLY.....	35
• EXPLODED VIEWS.....	36

LINES DESCRIPTION

Each step contains a variety of numbers, lines, and symbols. The numbers represent the order in which the parts should be assembled. The lines are described below.



Step number; the order in which you should assemble the indicated parts



Length after assembly



Assembly path of one item into another



Group of items (within lines) should be assembled first

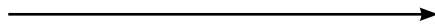

Direction the item should be moved



Glue one item to another



Press/insert one item into another



Connect one item to another



Gap between two items

ICONS DESCRIPTION

Each step contains a variety of symbols described below.



Carefully read and check thoroughly.



Apply a small amount of cyano glue. Use wear protection for eyes and hands.



Detail view to explain assembly or order of parts better.



Default set-up: This symbol indicates the default setup.



Grease: apply a small amount of grease to the parts shown.



Left and right parts should be assembled in the same way.



Thread lock: apply a small amount on the parts shown. Before to apply the threadlock, make sure to degrease the parts very well, as otherwise the threadlock will not work.



Silicone oil: use the indicated silicone oil for the shocks and differentials.



Parts or items not included in the kit.



Optional part, not standard in the kit.

CENTER DIFF ASSEMBLY

STEP 1

CENTER DIFF BAG

1.1

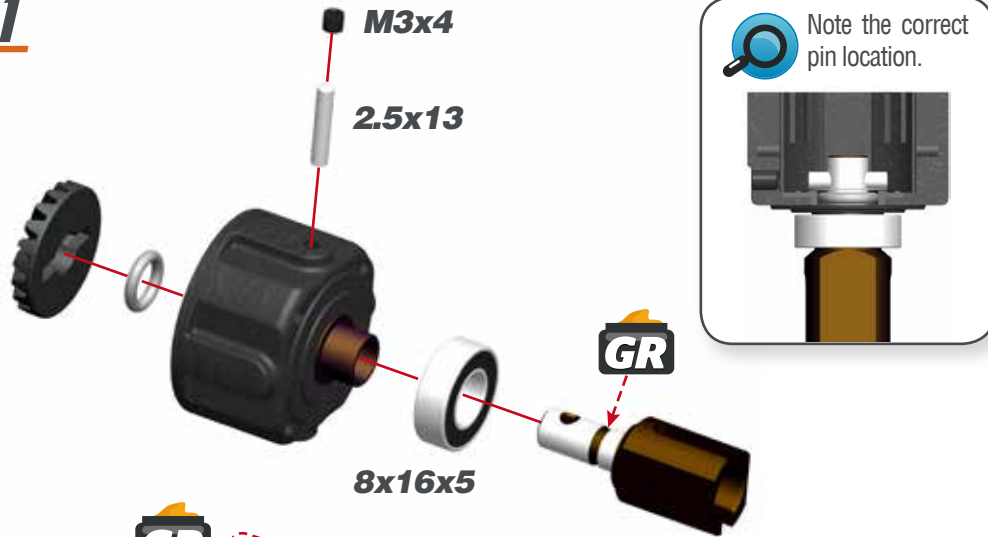

1.2

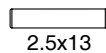
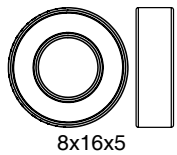
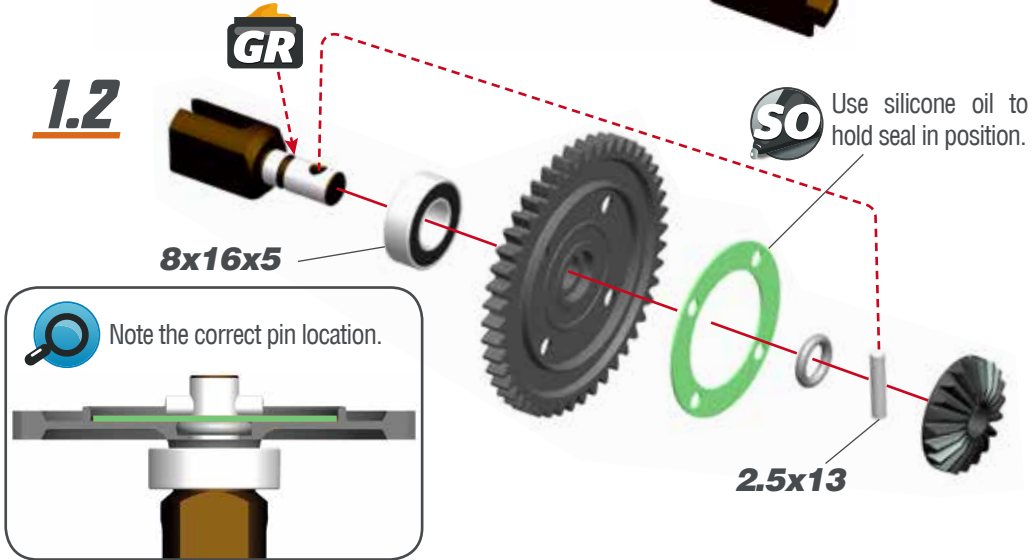

STEP 2

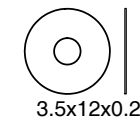
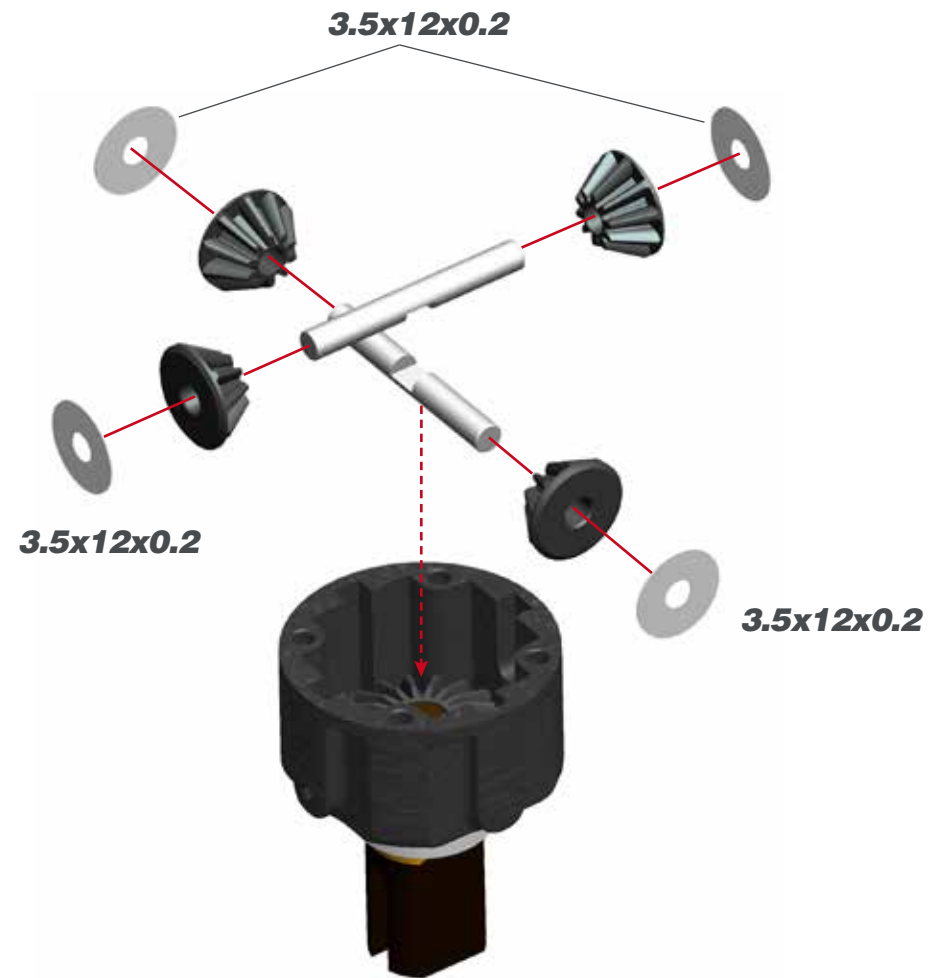

STEP 3



Fill the differential with silicone oil 1 mm above the crosspin, do NOT overfill. Use the silicone oil supplied in the kit. For the correct cst value please check the default setupsheet.

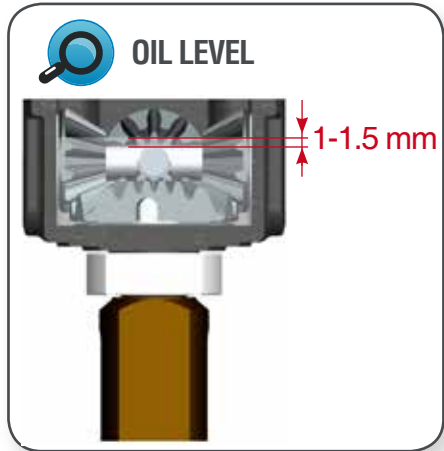

 **AMOUNT OF OIL IN THE DIFFS**

Use a digital scale to measure the exact amount of oil in the diff.

Differential Weight= 44.00 +/- 0.10 Gram



STEP 4

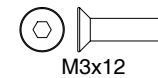
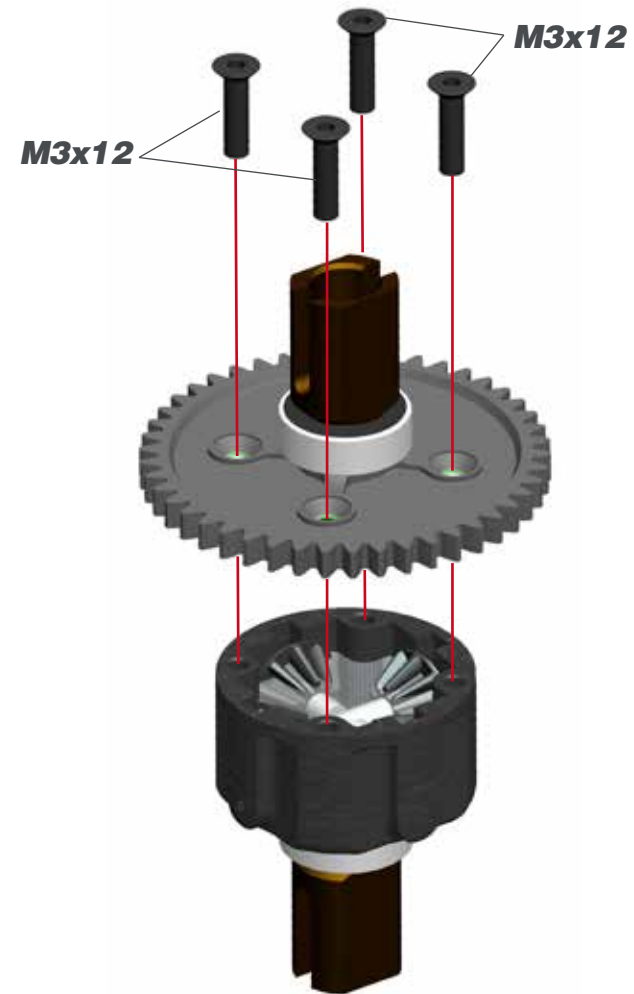

STEP 5

FR/RR DIFF BAG

5.1

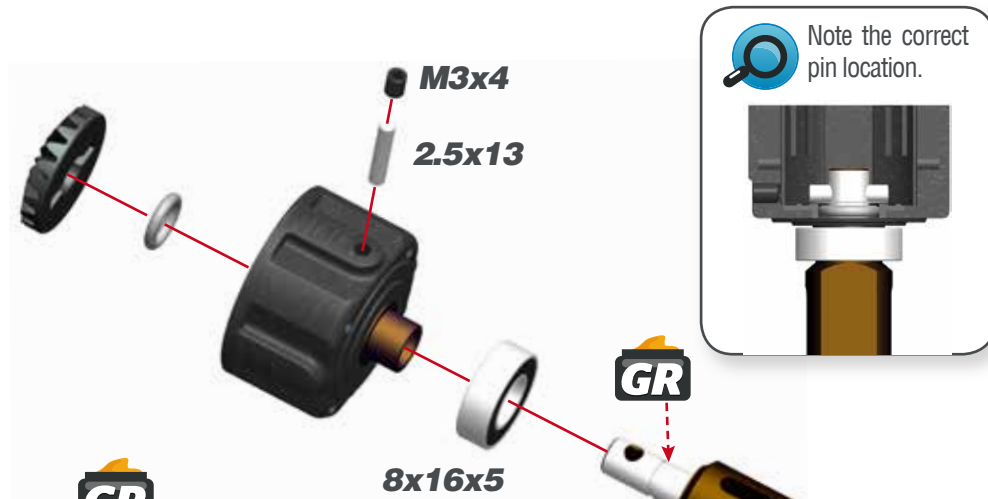

5.2

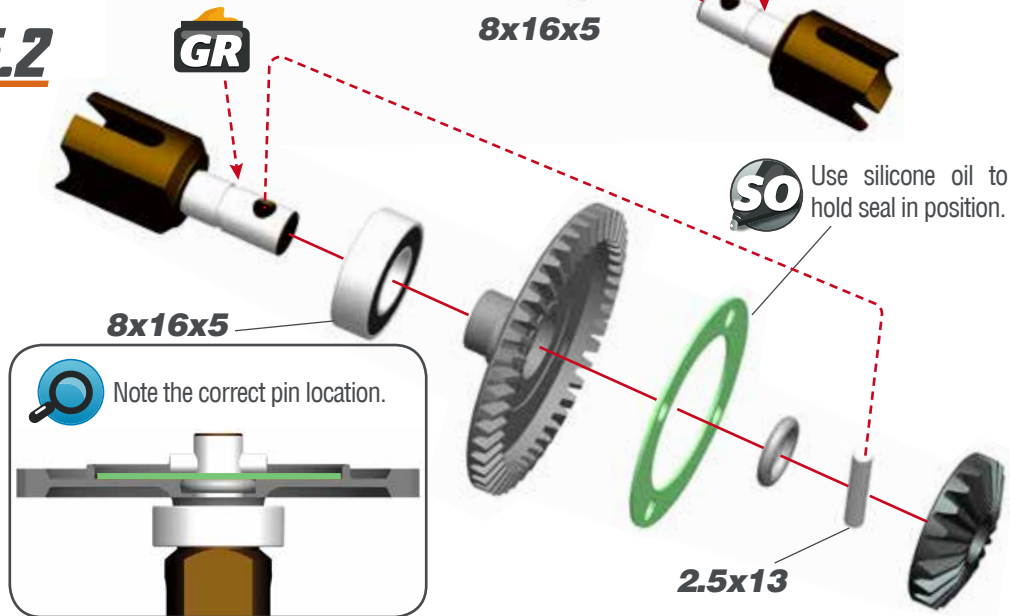

STEP 6

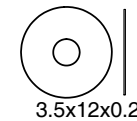
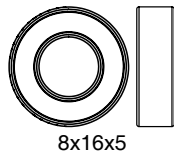
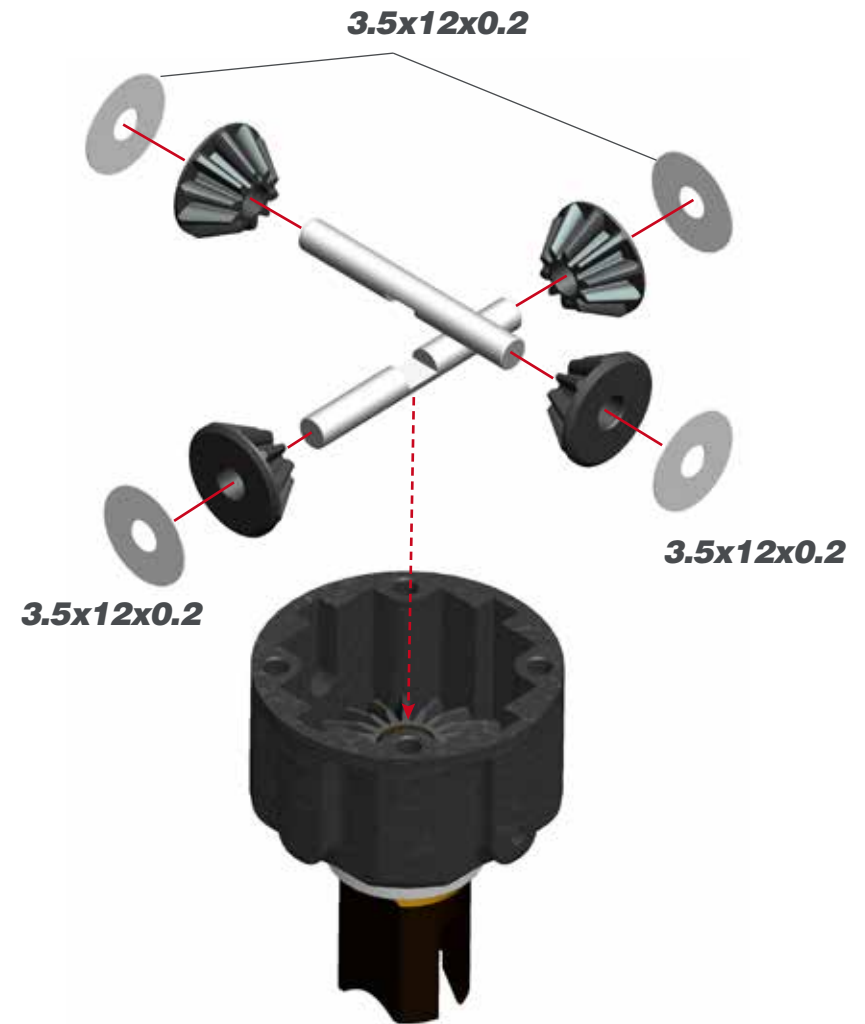

STEP 7



Fill the differential with silicone oil 1 mm above the crosspin, do NOT overfill. Use the silicone oil supplied in the kit. For the correct cst value please check the default setupsheet.



OIL LEVEL

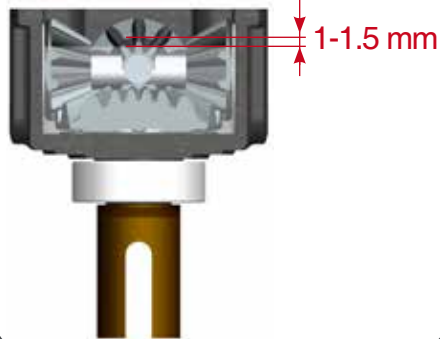

AMOUNT OF OIL IN THE DIFFS

Use a digital scale to measure the exact amount of oil in the diff.

Differential Weight= 43.50 +/- 0.10 Gram



STEP 8

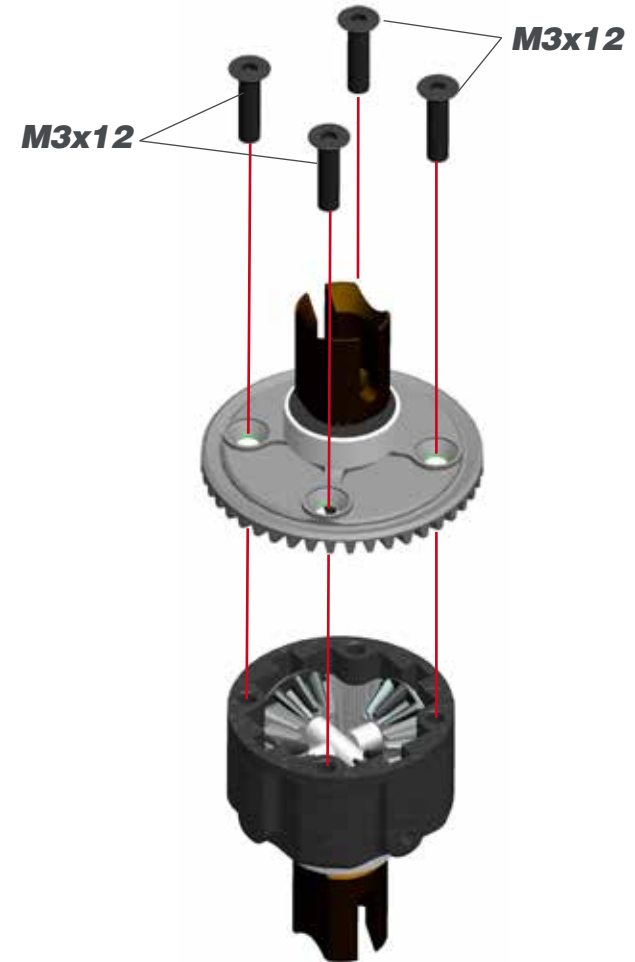

M3x12

STEP 9

BAG 1

STEP 10

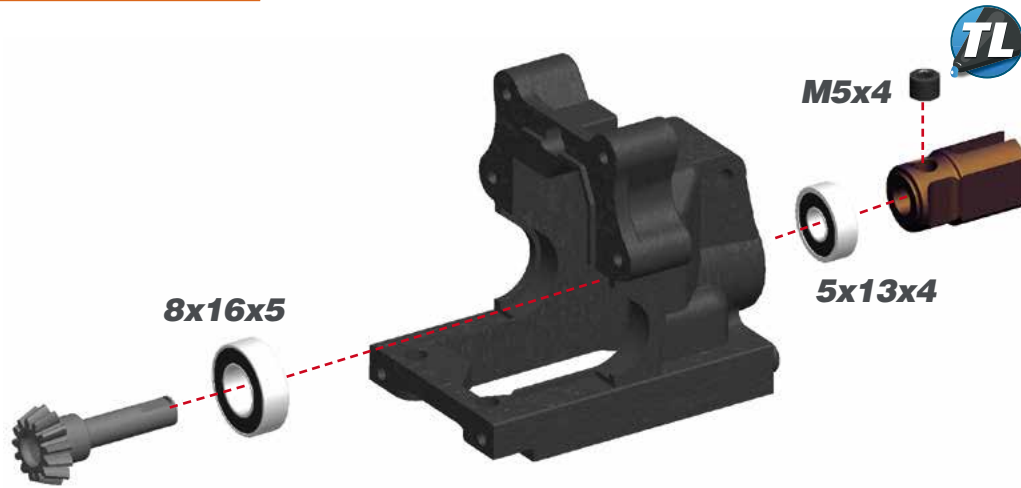

After building the differential with new gears, new differential case and bearings, the diff may feel a little tight. The connected parts need at least an hour run-time to create a perfect match. Attention: When you assemble the diff with too much initial play, the gears will not run-in properly and may wear quickly. After 1 or 2 hours of running the car, re-check the gear-mesh between the ring gear and the pinion. All parts should have run-in properly now. You may add or remove 8x11x0.1 shims as needed.

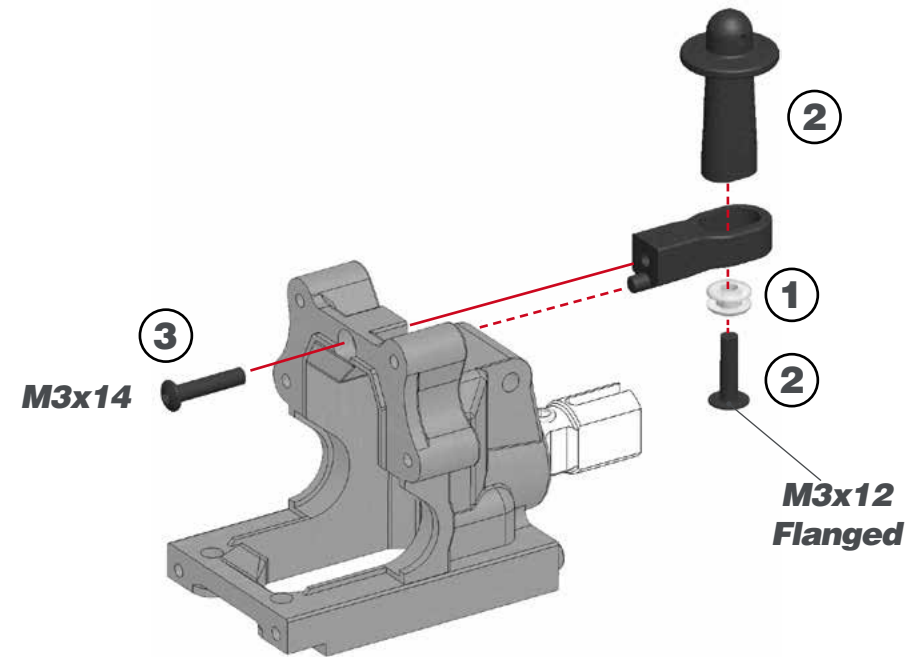

Note the correct grommet position.

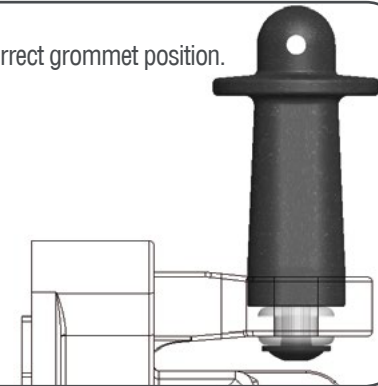

M5x4

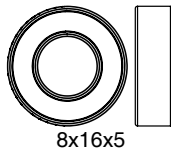

8x16x5

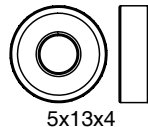

5x13x4

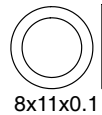

8x11x0.1

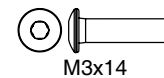

M3x14



M3x12 Flanged

STEP 11

11.1

! After 1 or 2 hours of running the car, re-check the gear-mesh between the ring gear and the pinion. All parts should have run-in properly. You may add or remove 13x16x0.1 shims as needed.

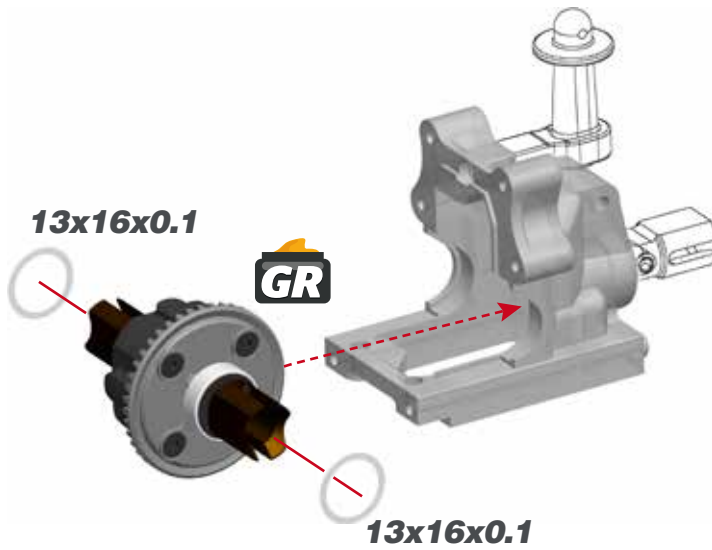

11.2

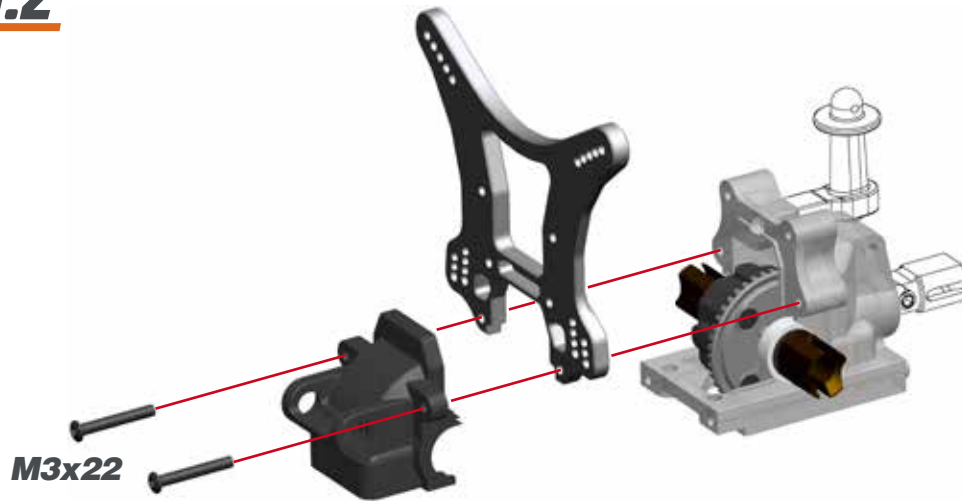

M3x22

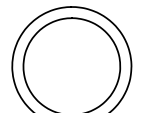

13x16x0.1

STEP 12

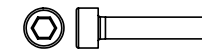
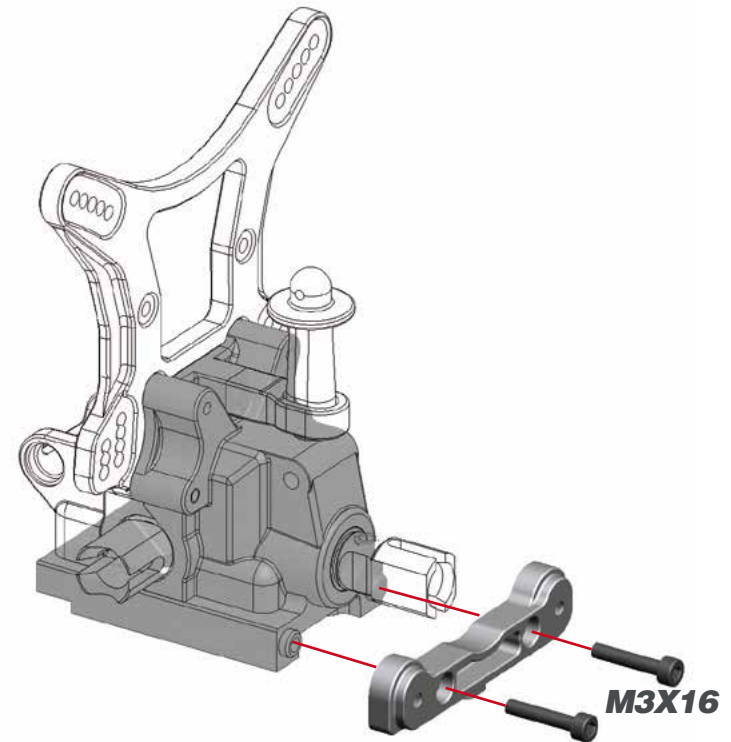

M3x16

STEP 13 BAG 2

STEP 14

13.1

L=R



Tighten anti-roll bar cap until there is no play, and it moves freely.

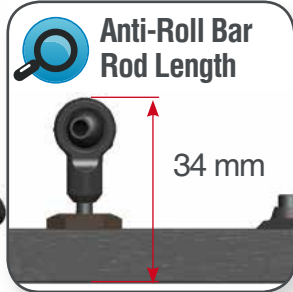

13.2

M2.5X6

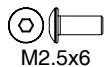

4 **M3X16**

3

2

1

L=R **REAR TOE IN INSERTS CHART**

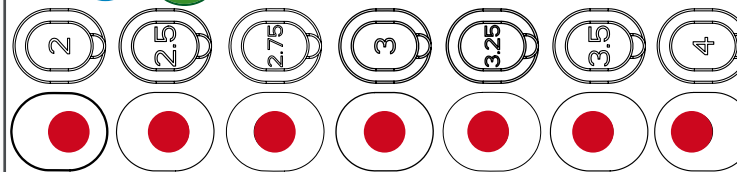

L=R **Anti-squat insert chart**

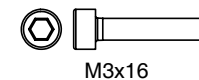
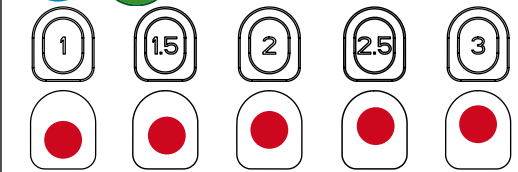

STEP 15

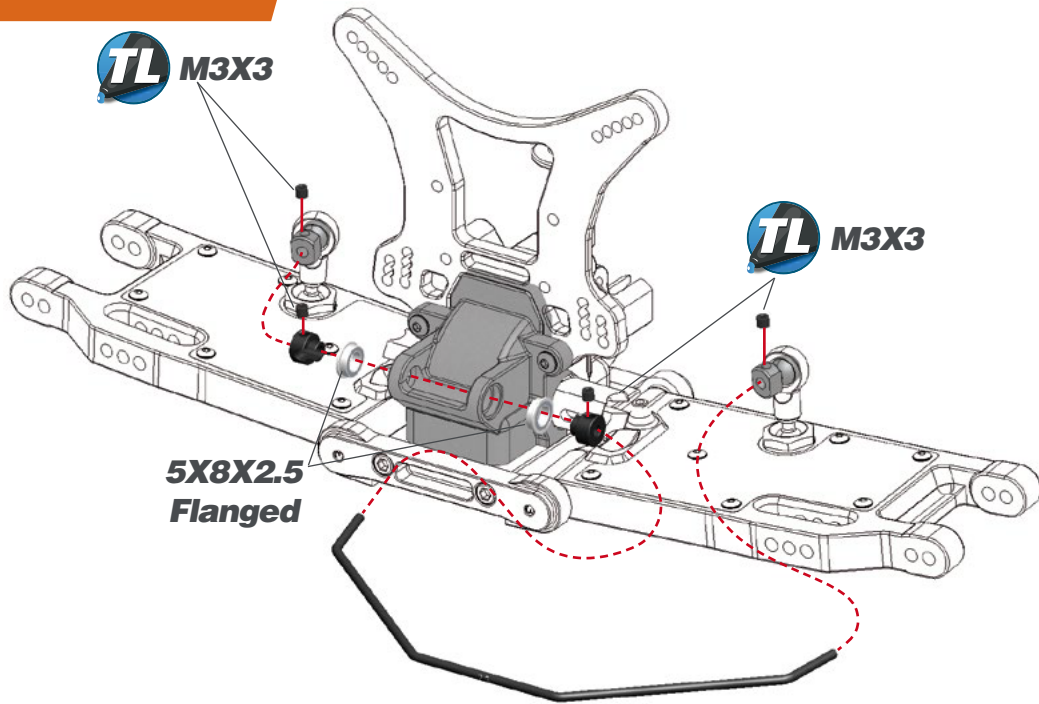

TL M3X3

TL M3X3

5X8X2.5
Flanged

REAR ANTI-ROLL BAR ASSEMBLY

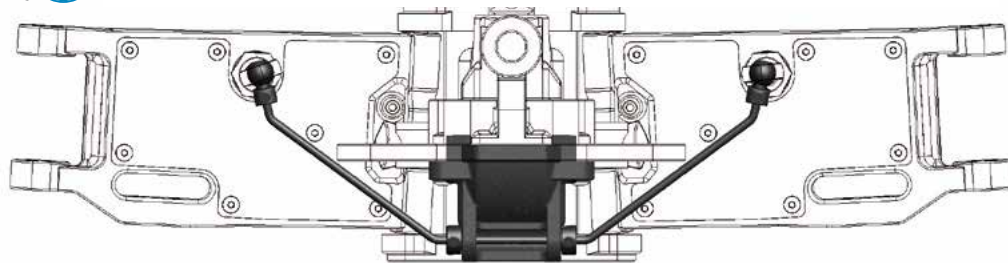

5X8X2.5 Flanged



M3x3

STEP 16

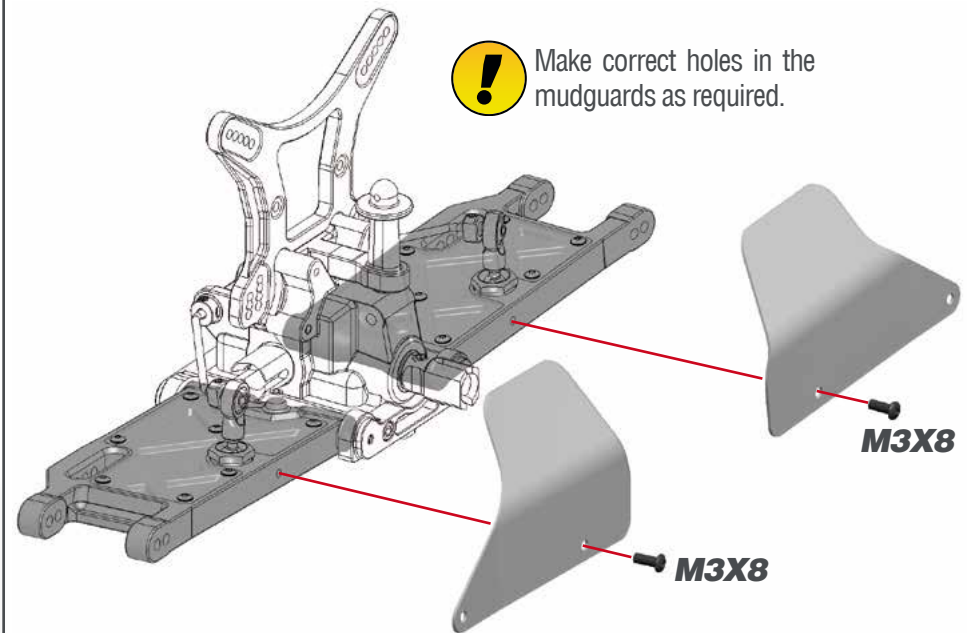

! Make correct holes in the mudguards as required.

M3X8

M3X8



M3x8

STEP 17 BAG 3

17.1 L=R

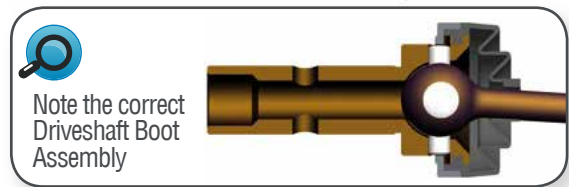
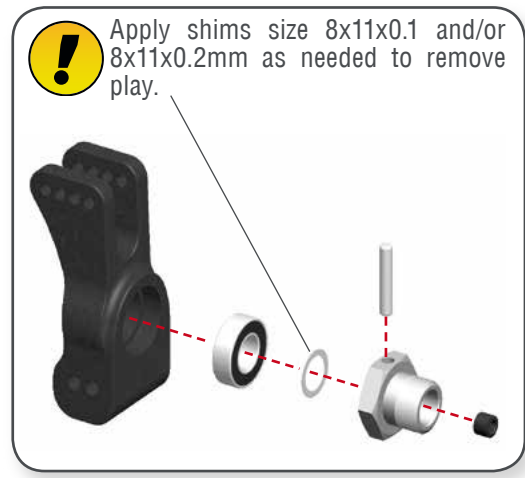
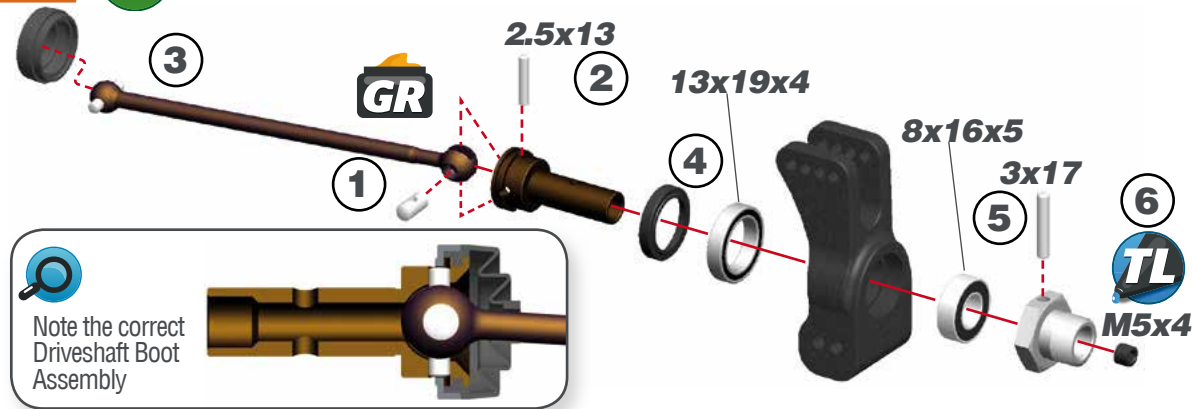

17.2

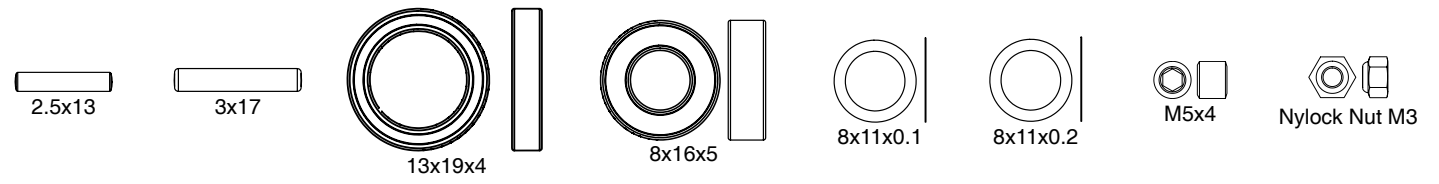
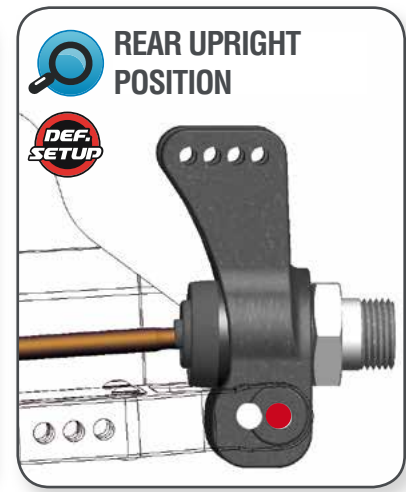
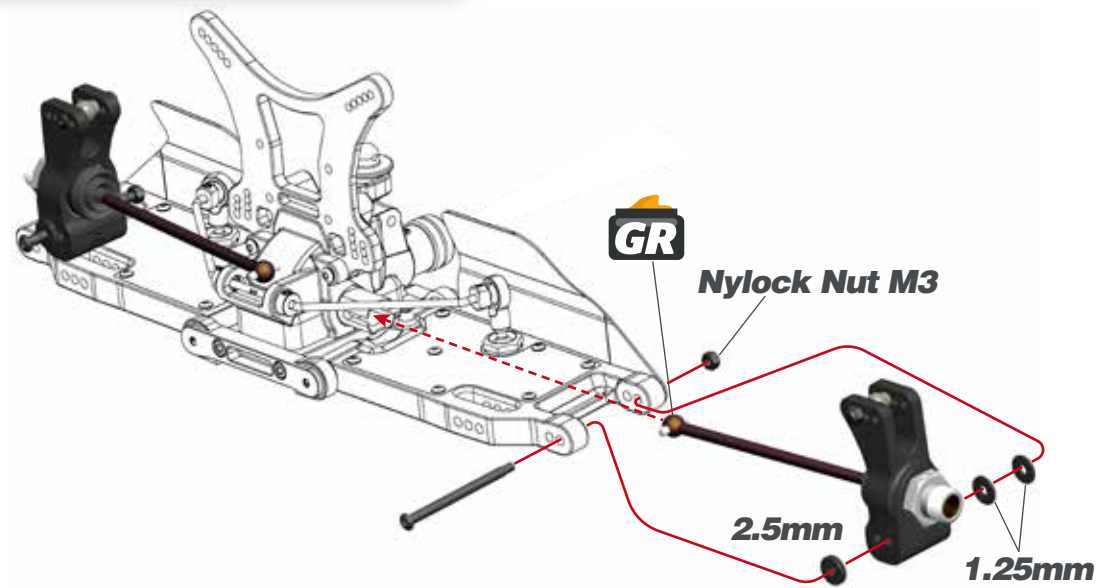

STEP 18 BAG 4

18.1

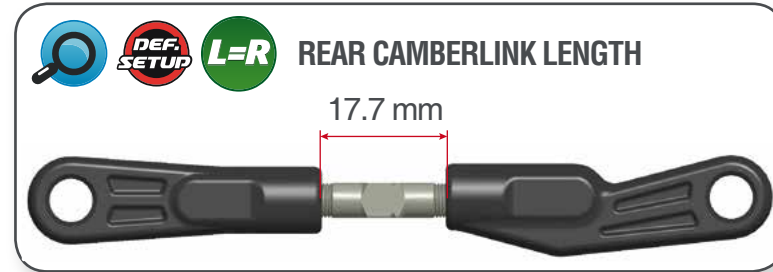

18.2

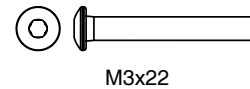
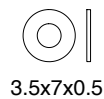
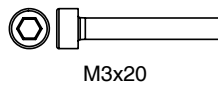
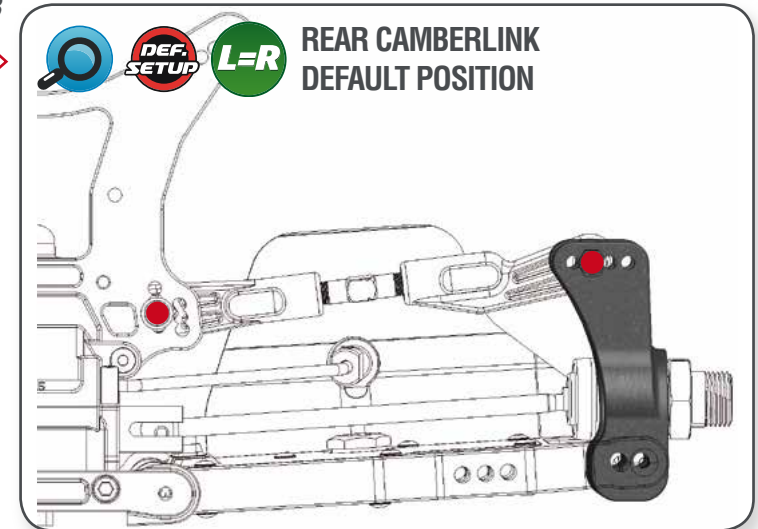
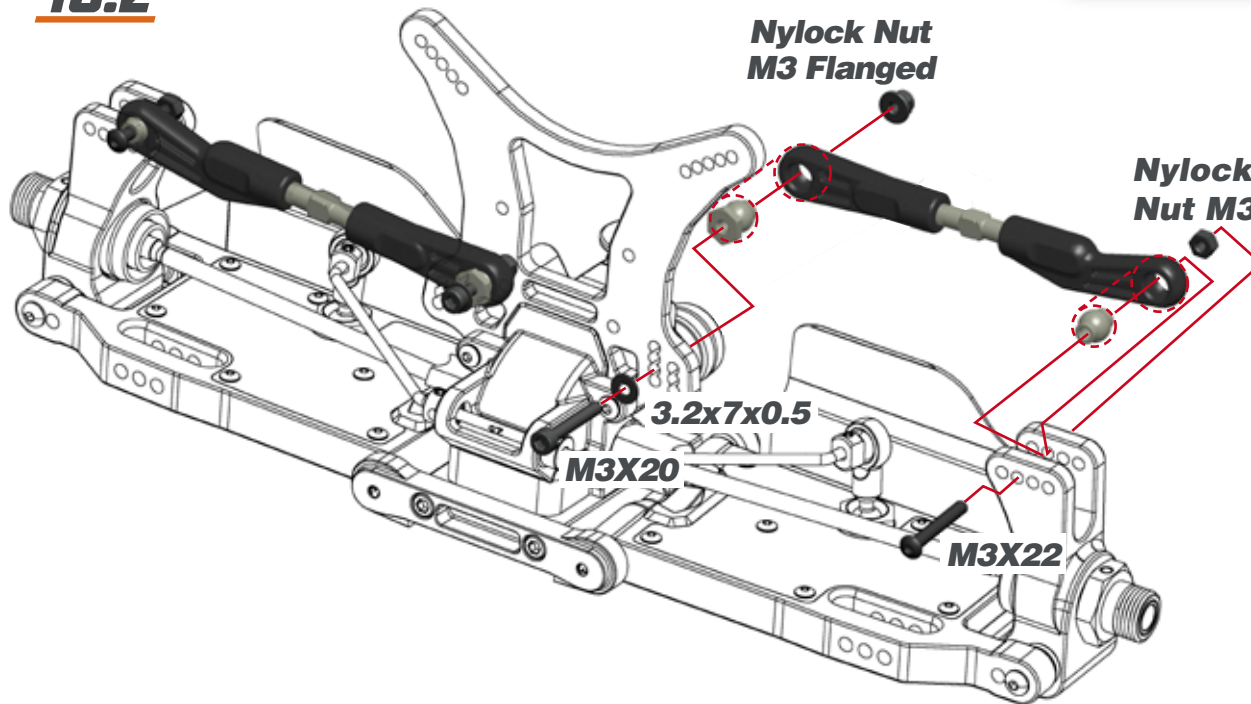

STEP 19

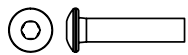
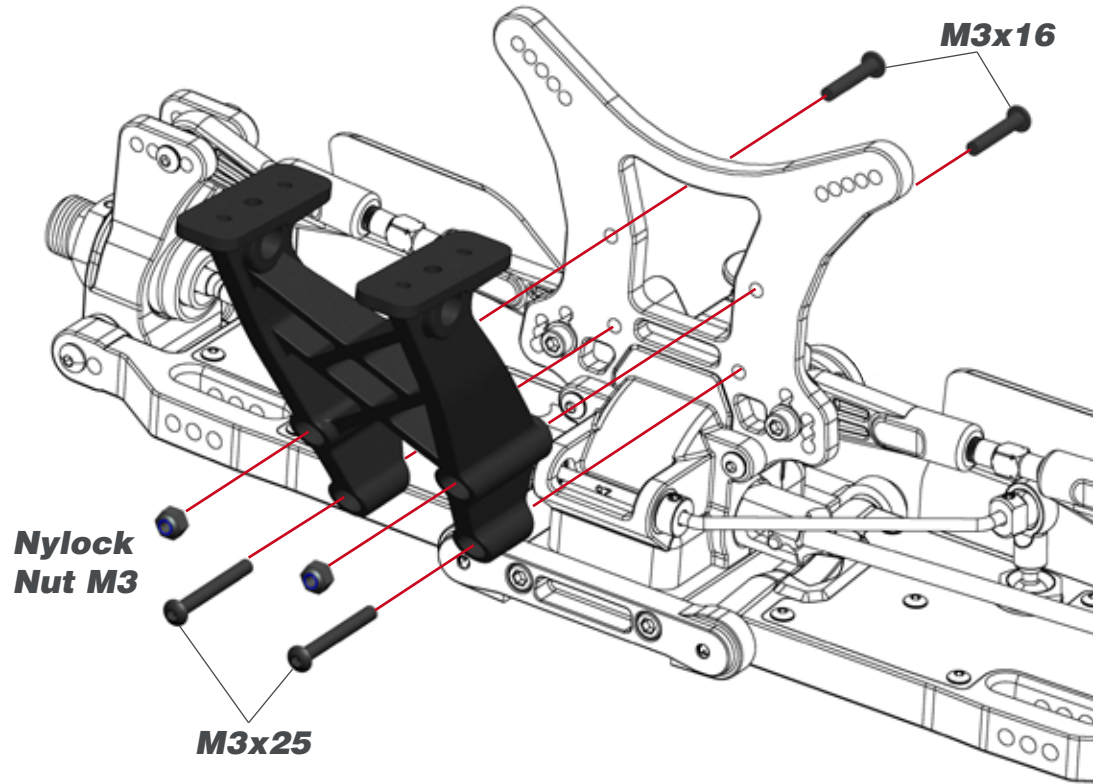

M3x16

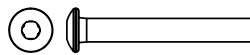

M3x25



Nylock Nut M3

STEP 20

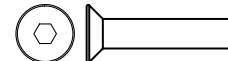
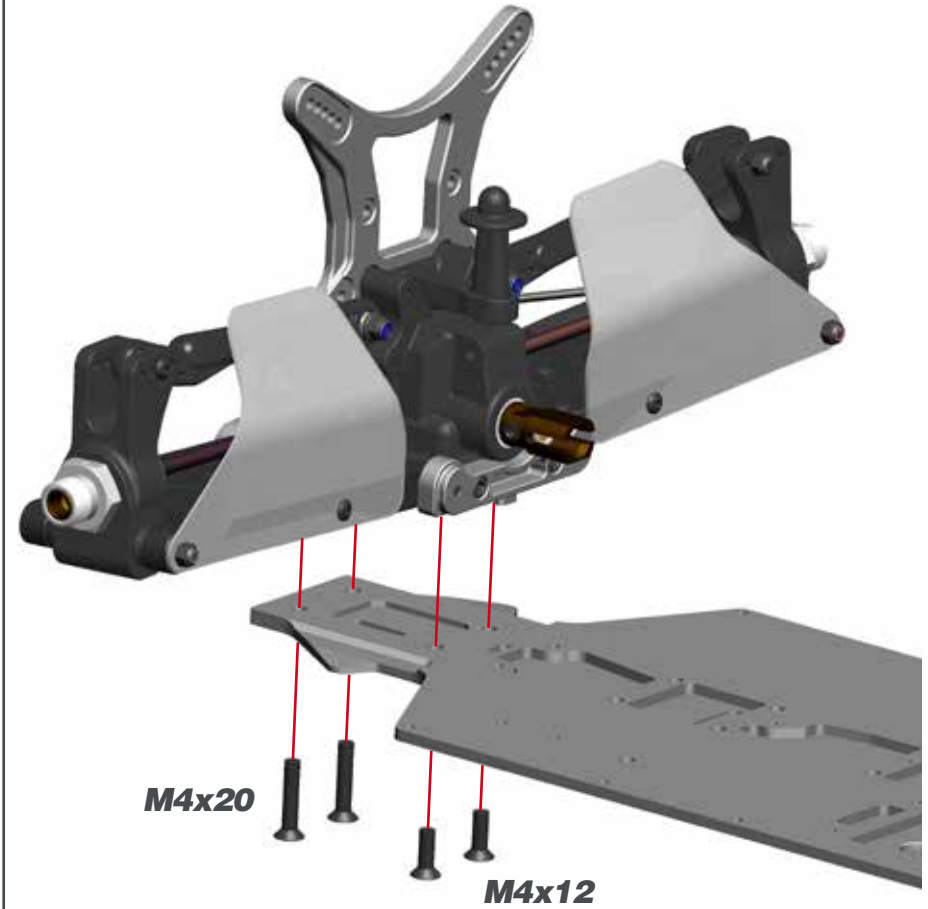

M4x20



M4x12

STEP 21

BAG 5

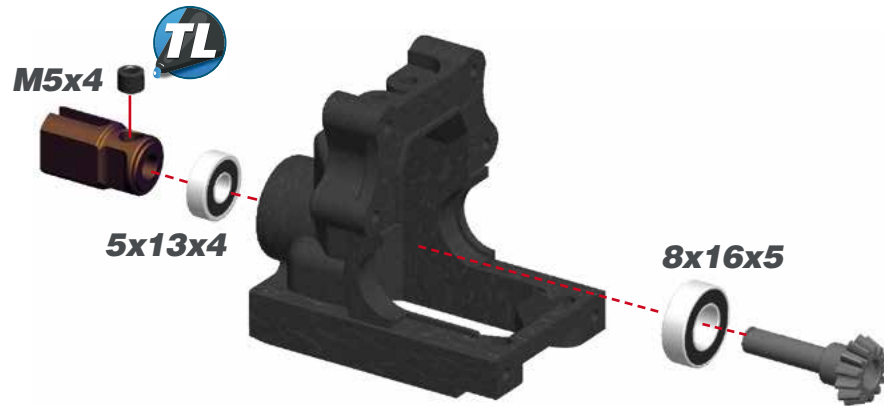



STEP 22

22.1

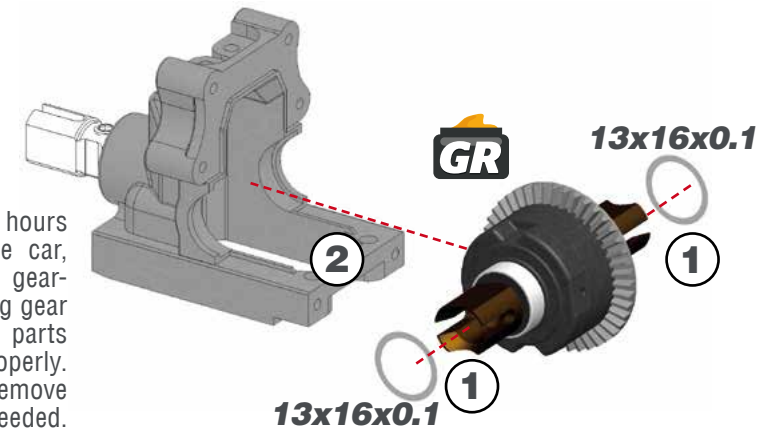
! After 1 or 2 hours of running the car, re-check the gear-mesh between the ring gear and the pinion. All parts should have run-in properly. You may add or remove 13x16x0.1 shims as needed.

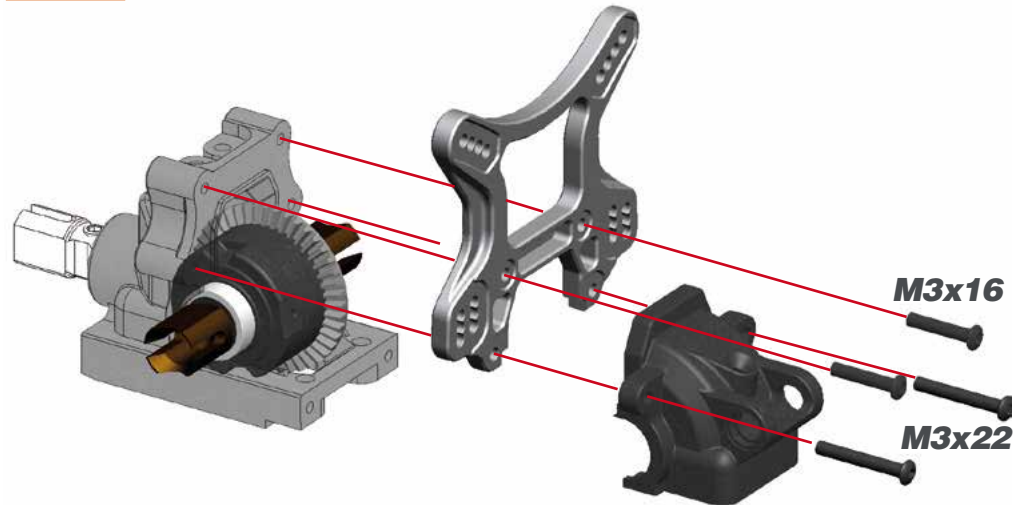

22.2

After building the differential with new gears, new differential case and bearings, the diff may feel a little tight. The connected parts need at least an hour run-time to create a perfect match. Attention: When you assemble the diff with too much initial play, the gears will not run-in properly and may wear quickly. After 1 or 2 hours of running the car, re-check the gear-mesh between the ring gear and the pinion. All parts should have run-in properly now. You may add or remove 8x11x0.1 shims as needed.



8x11x0.1

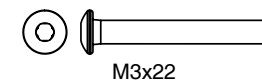
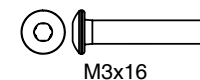
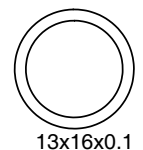
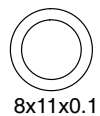
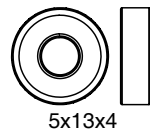
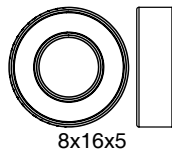

STEP 23

STEP 24 BAG 6

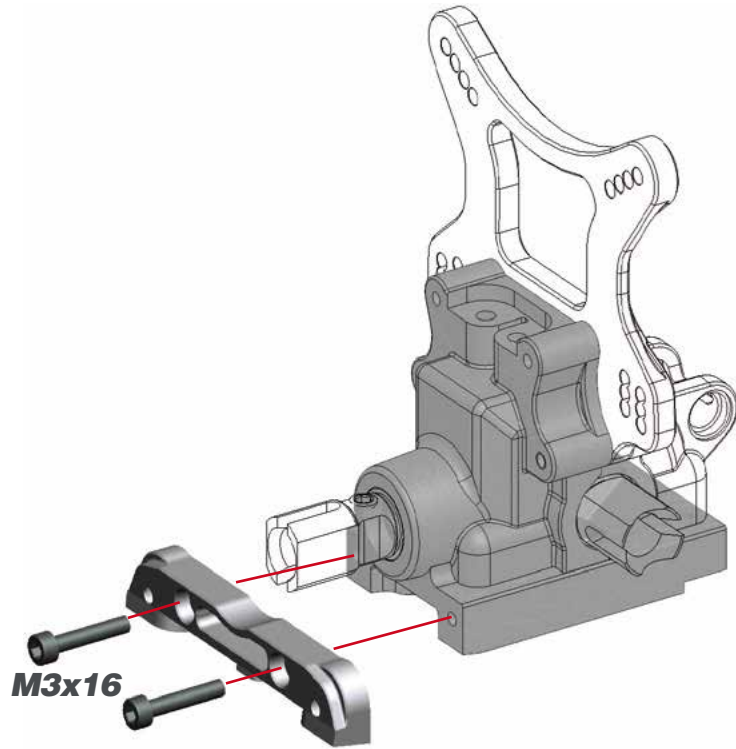

M3x16

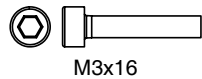

M3x16

24.1

L=R



Tighten anti-roll bar cap until there is no play, and it moves freely.



24.2

L=R



M2.5X6

M2.5X6



M2.5x6

STEP 25

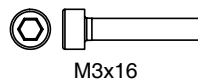
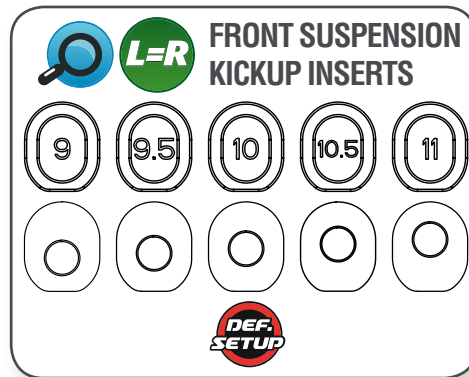
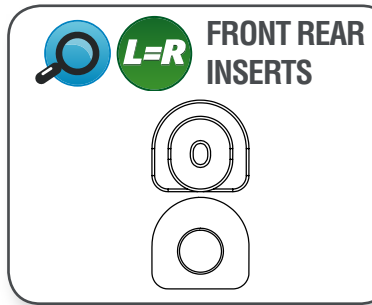
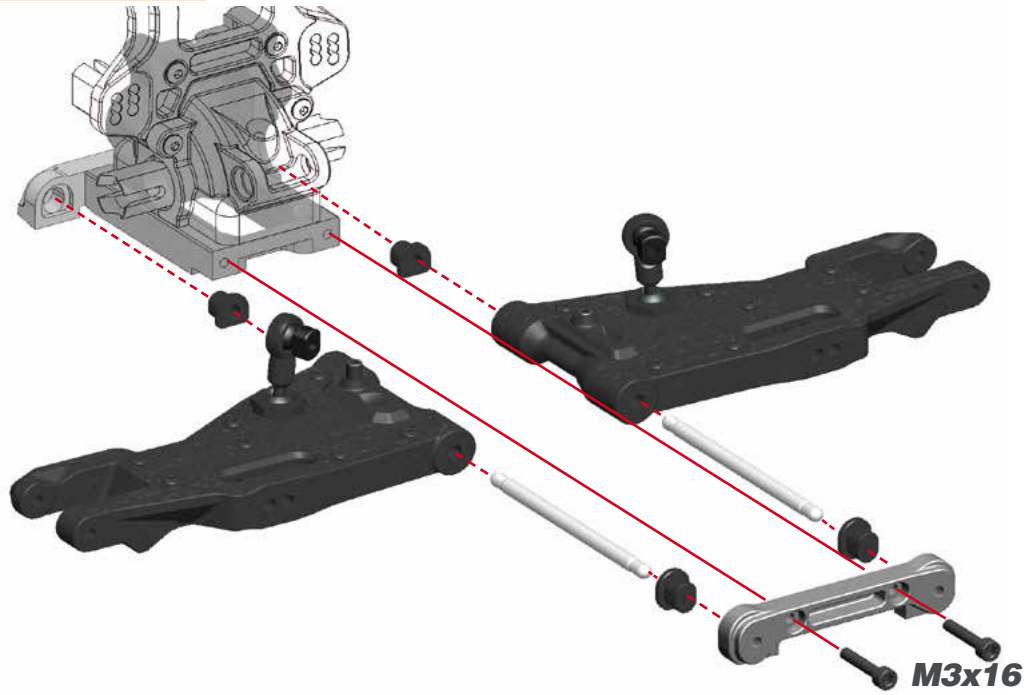

STEP 26

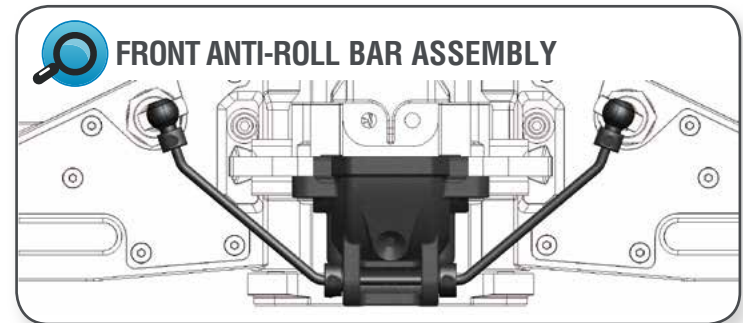
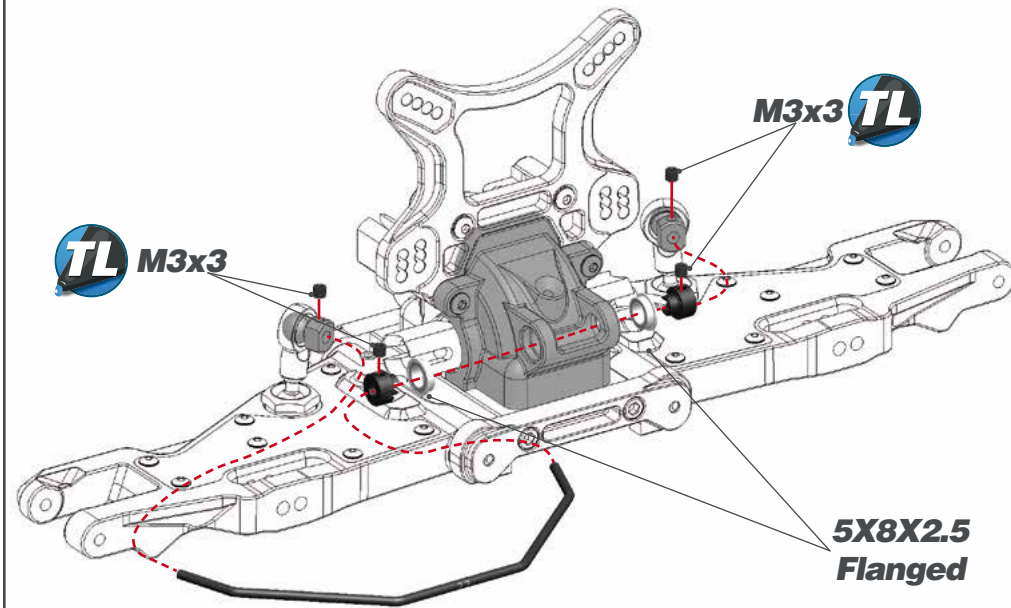

STEP 27 BAG 7

27.1 L=R

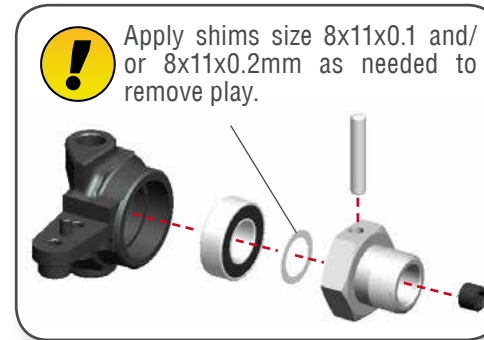
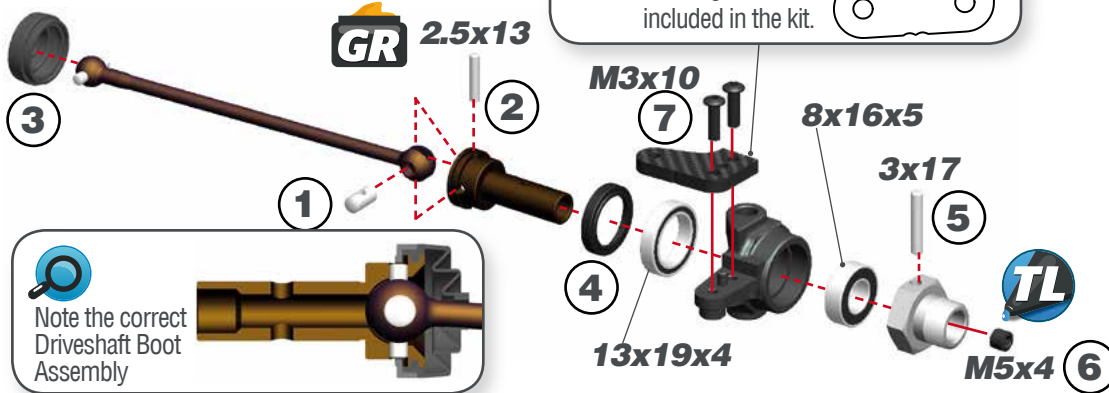

27.2

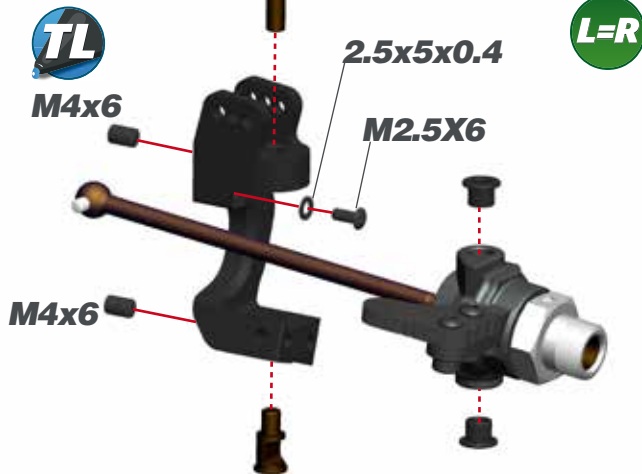

27.3

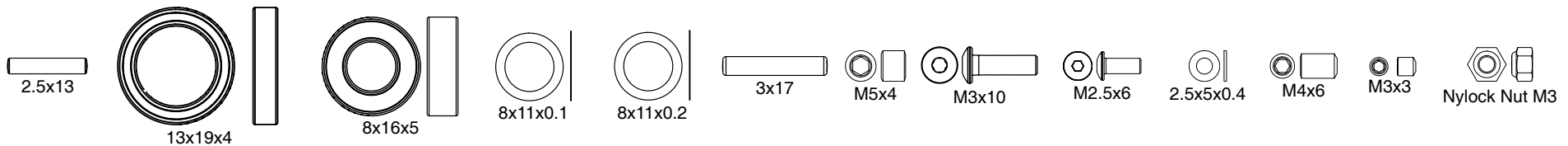
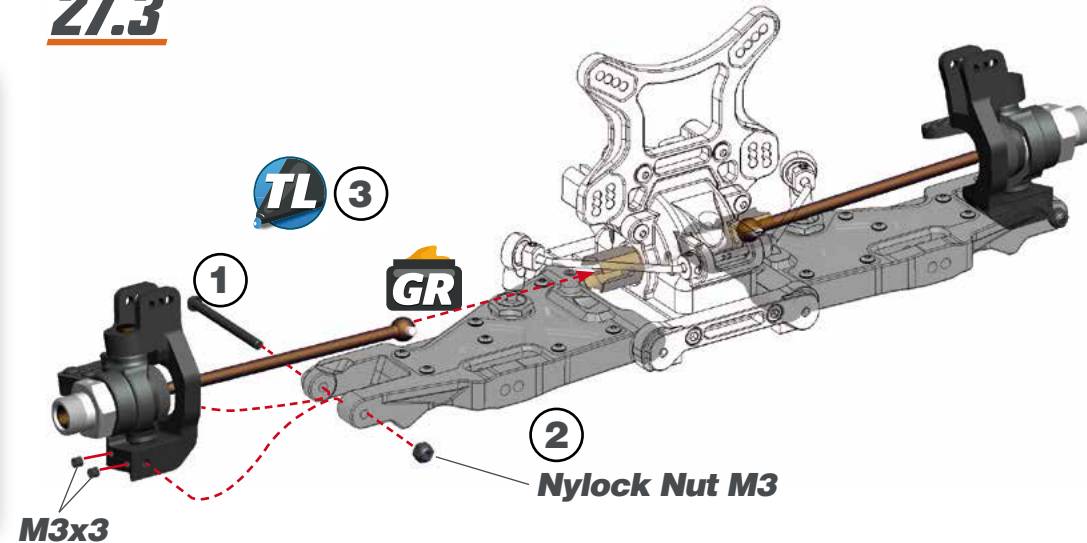

STEP 28 BAG 8

28.1

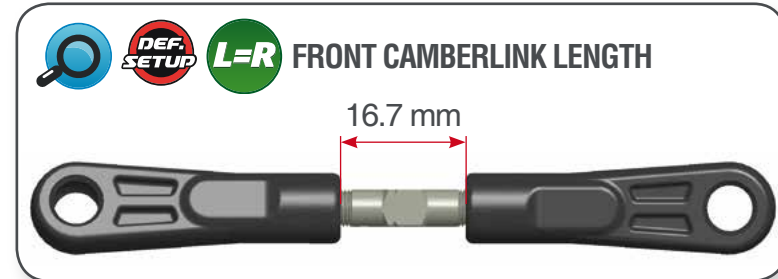

28.2

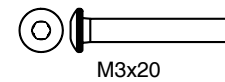
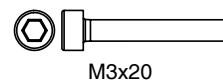
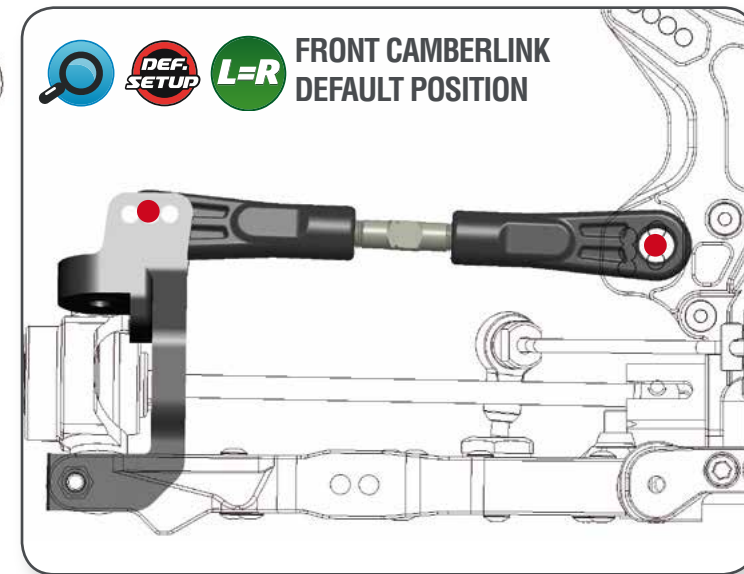
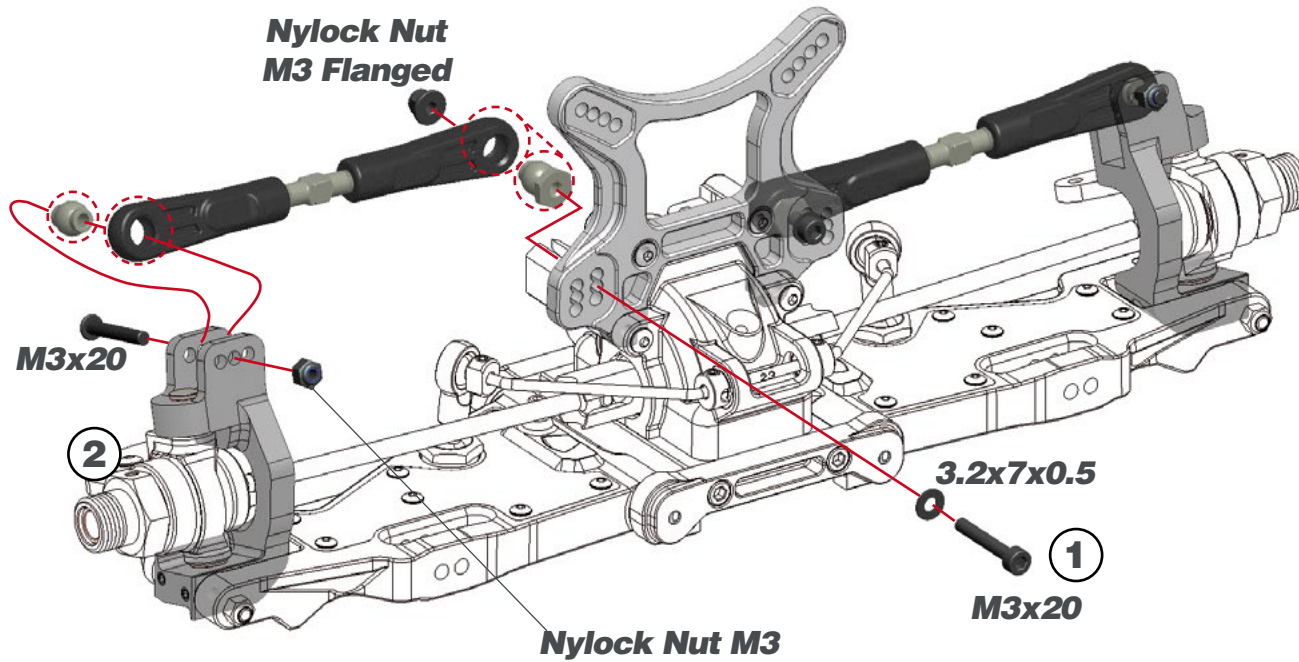

STEP 29

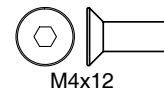
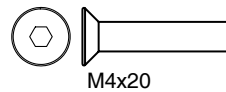
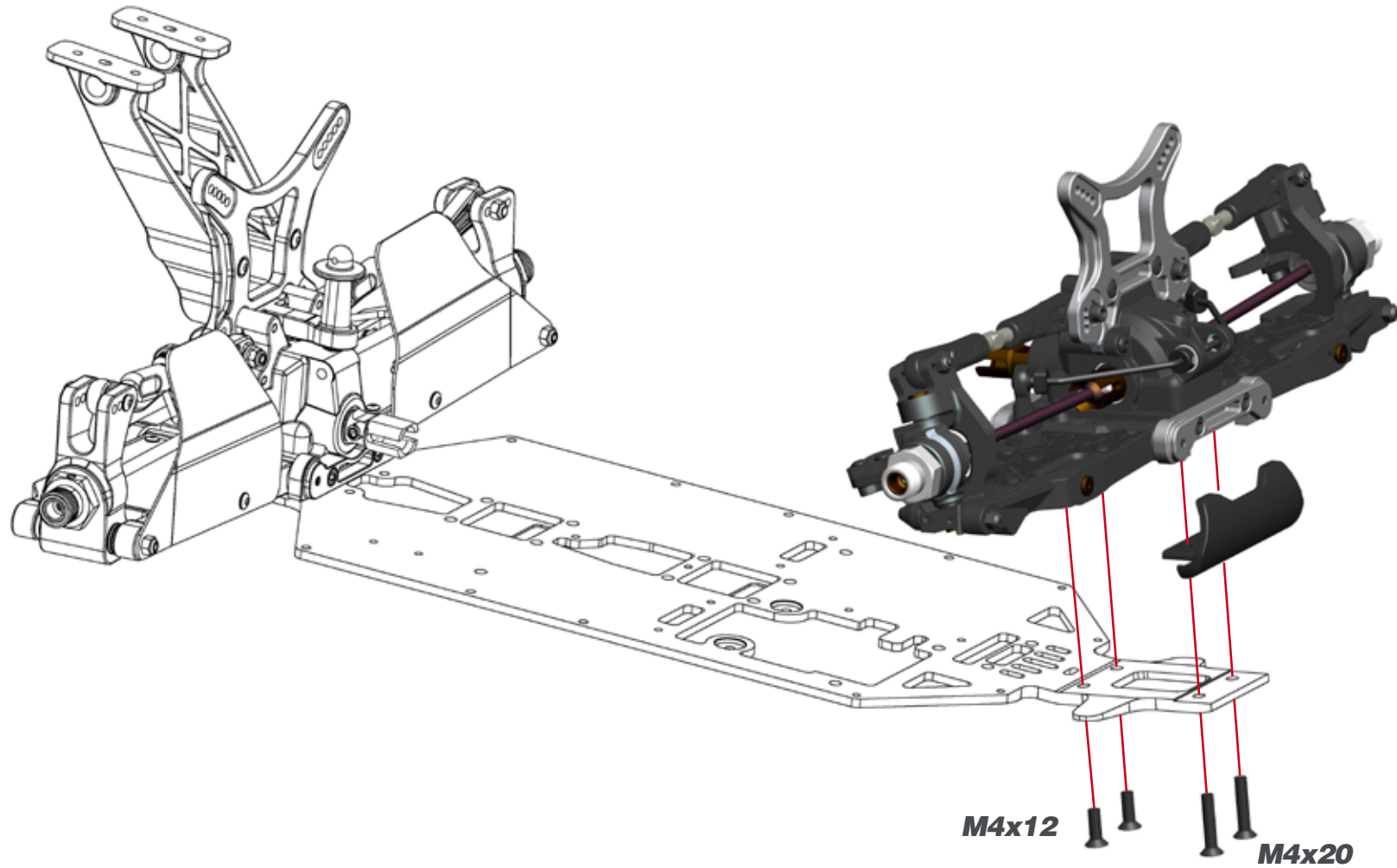

STEP 30

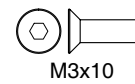
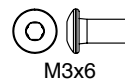
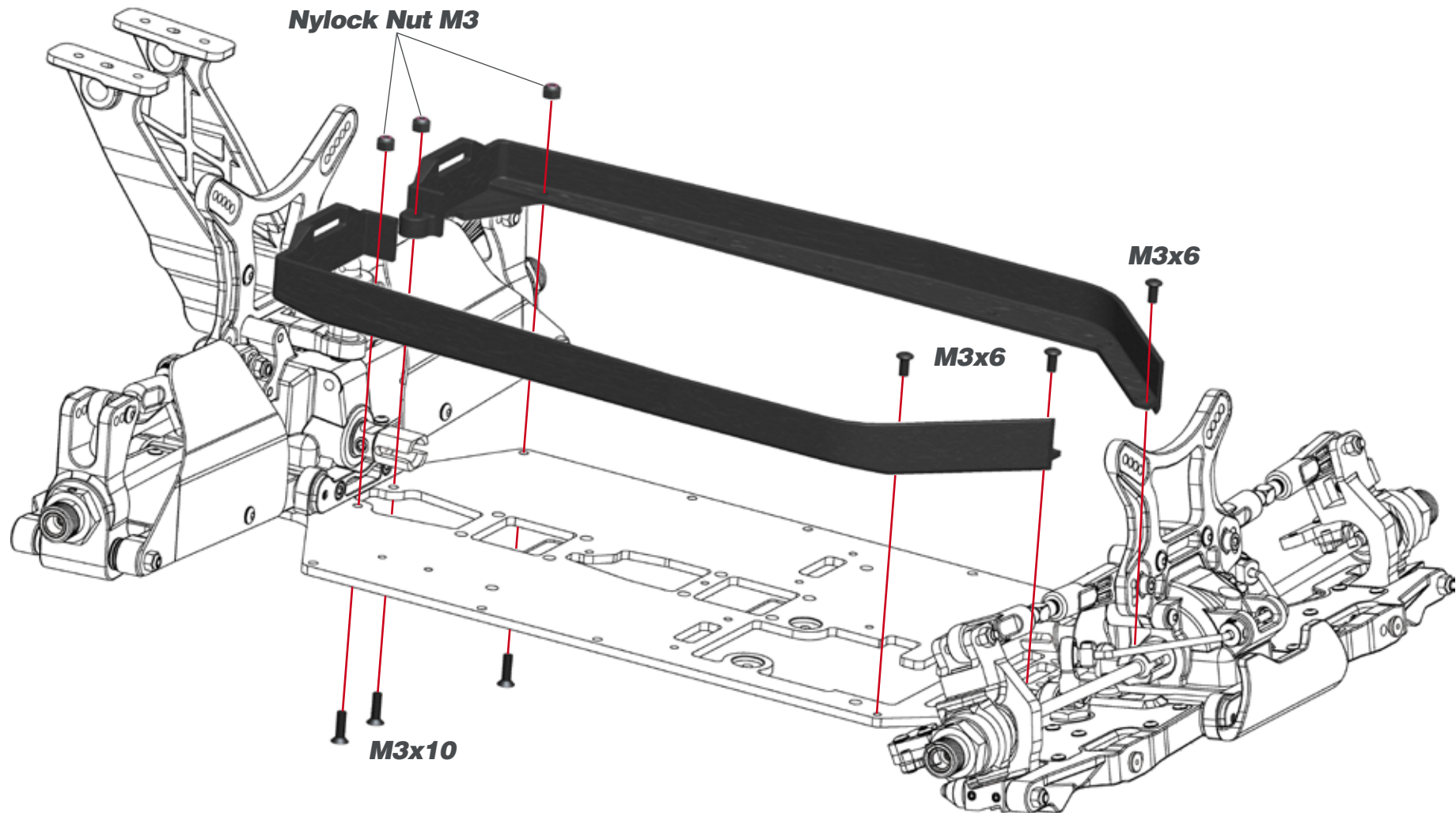

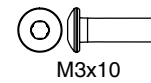
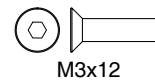
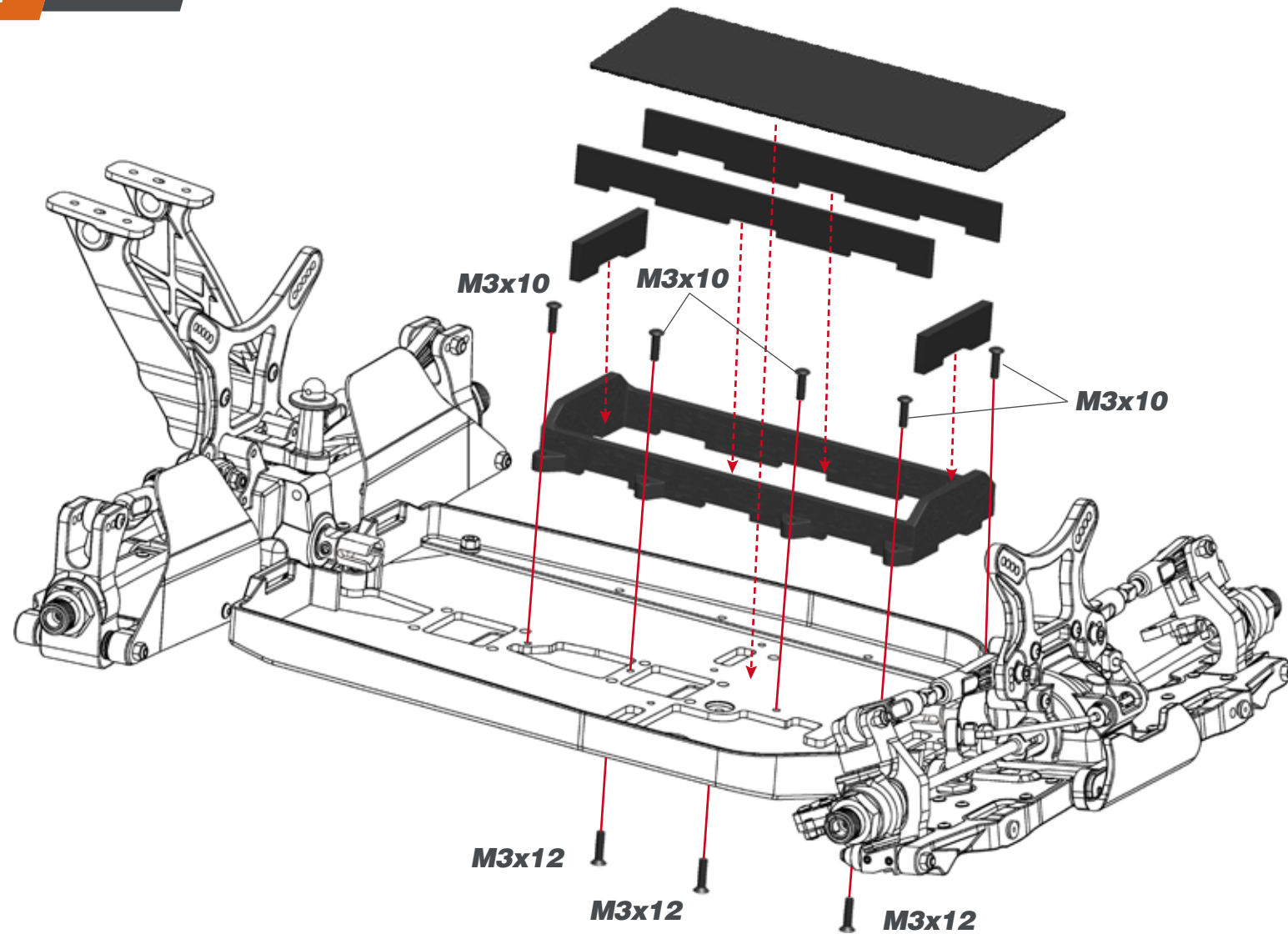

STEP 32

STEP 33

32.1

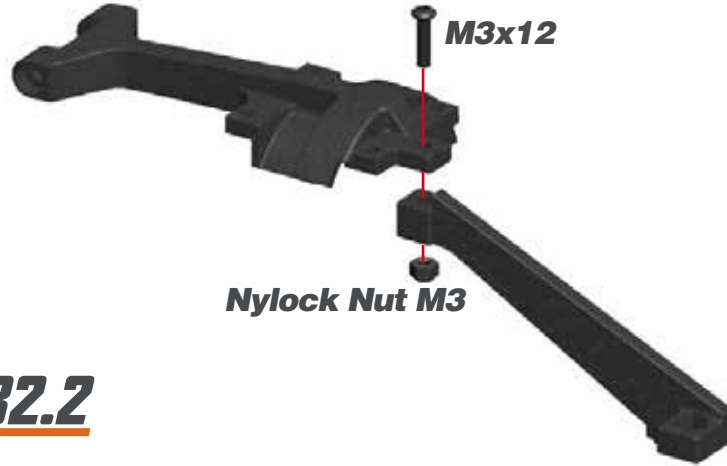

32.2

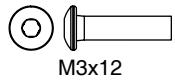
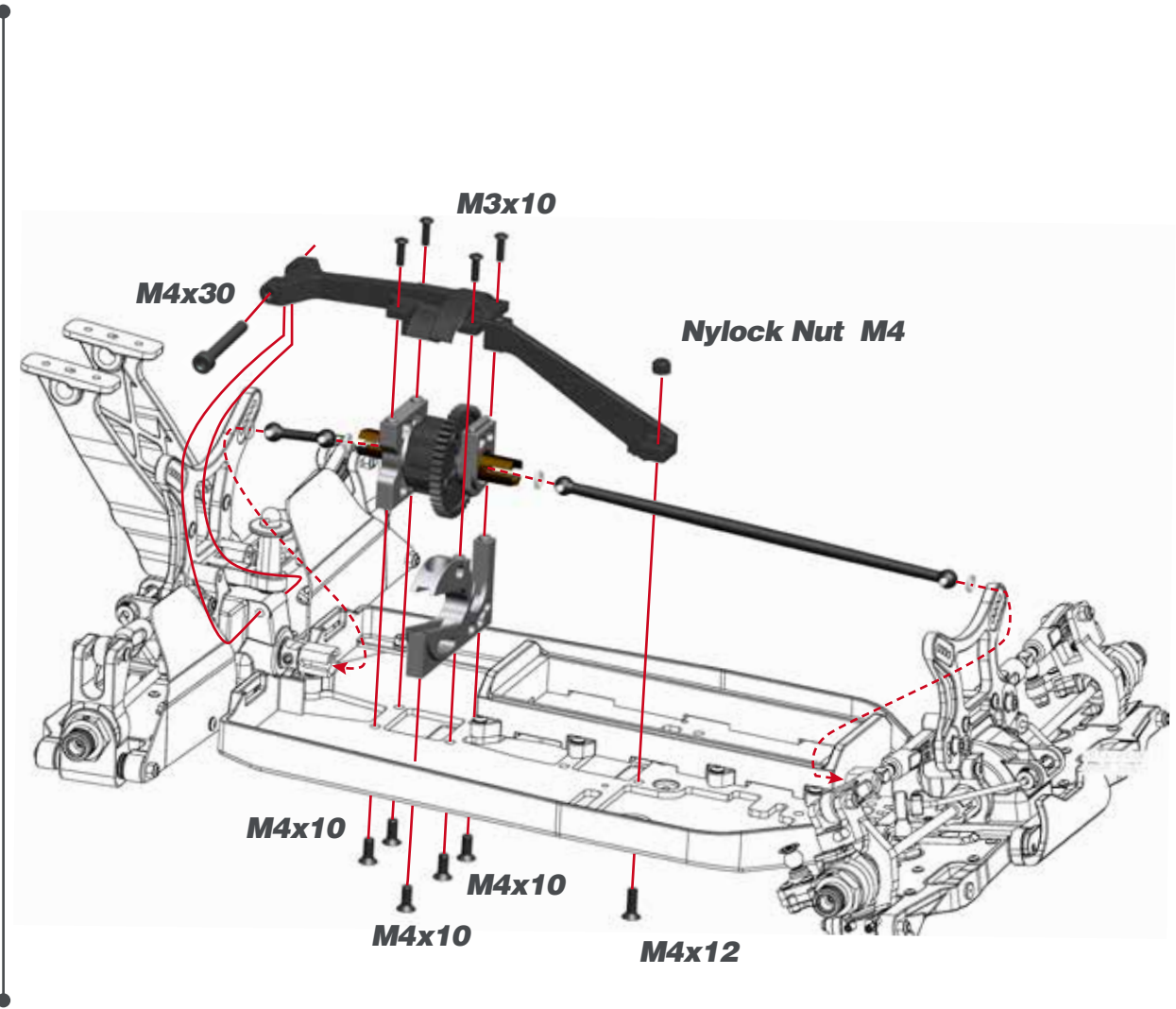
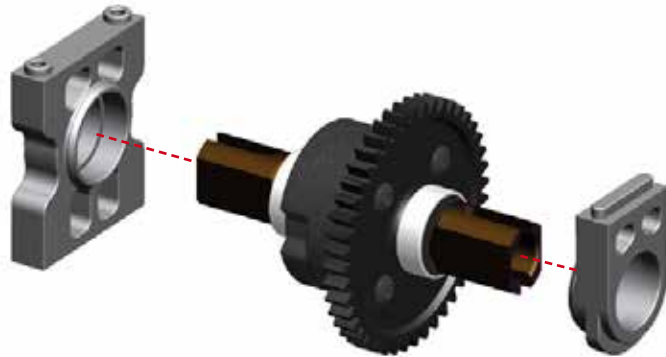

M3x12



Nylock Nut M3

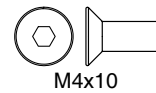

M4x10

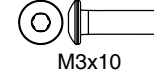

M3x10



M4x12



Nylock Nut M4

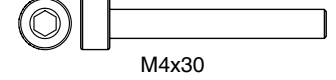

M4x30

STEP 34 BAG 10

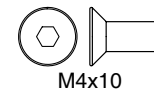
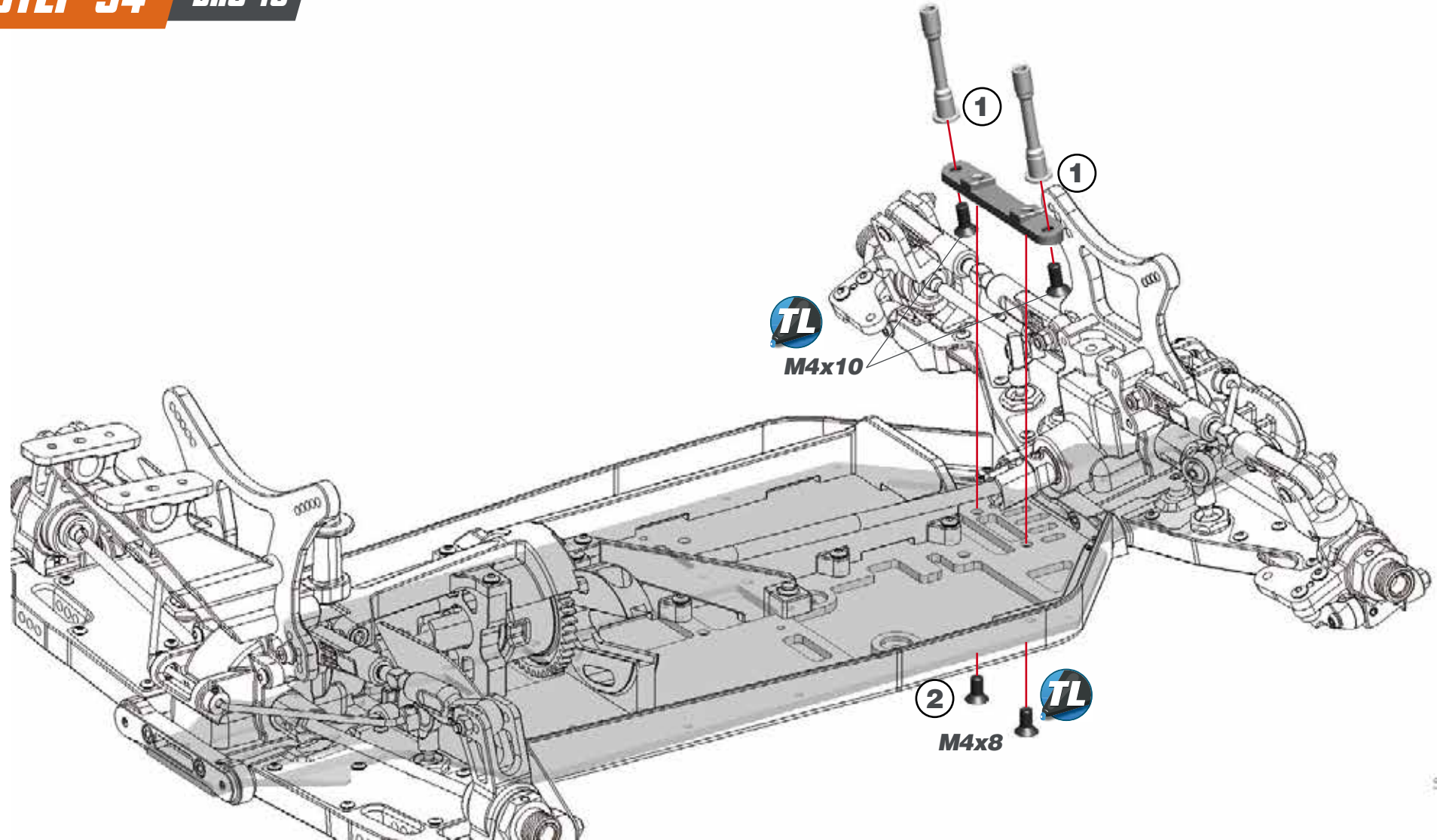

STEP 35

35.1



M2x10

35.2

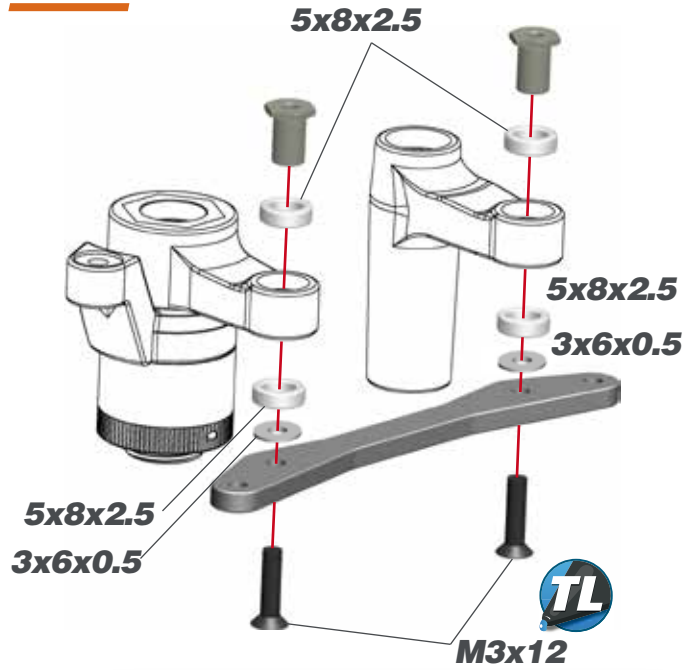

5x8x2.5
3x6x0.5

M3x12



3.5 mm

STEP 36

36.1



STEERING TRACKROD LENGTH

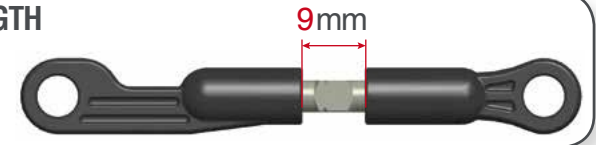

9mm

36.2

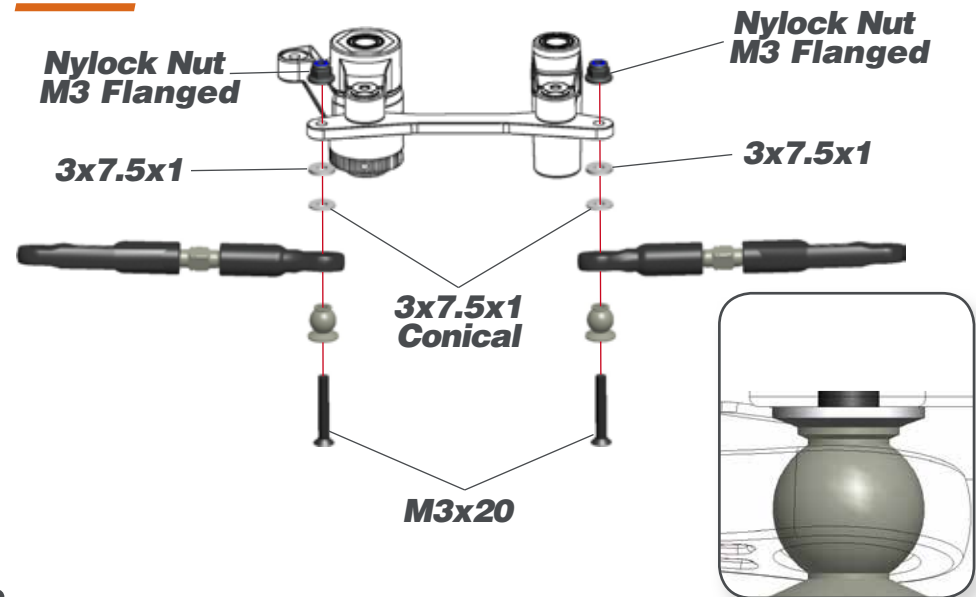

Nylock Nut
M3 Flanged

Nylock Nut
M3 Flanged

3x7.5x1

3x7.5x1

3x7.5x1
Conical

M3x20

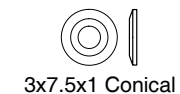
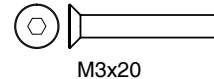
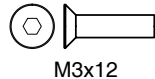
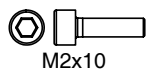

STEP 37

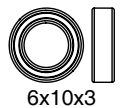
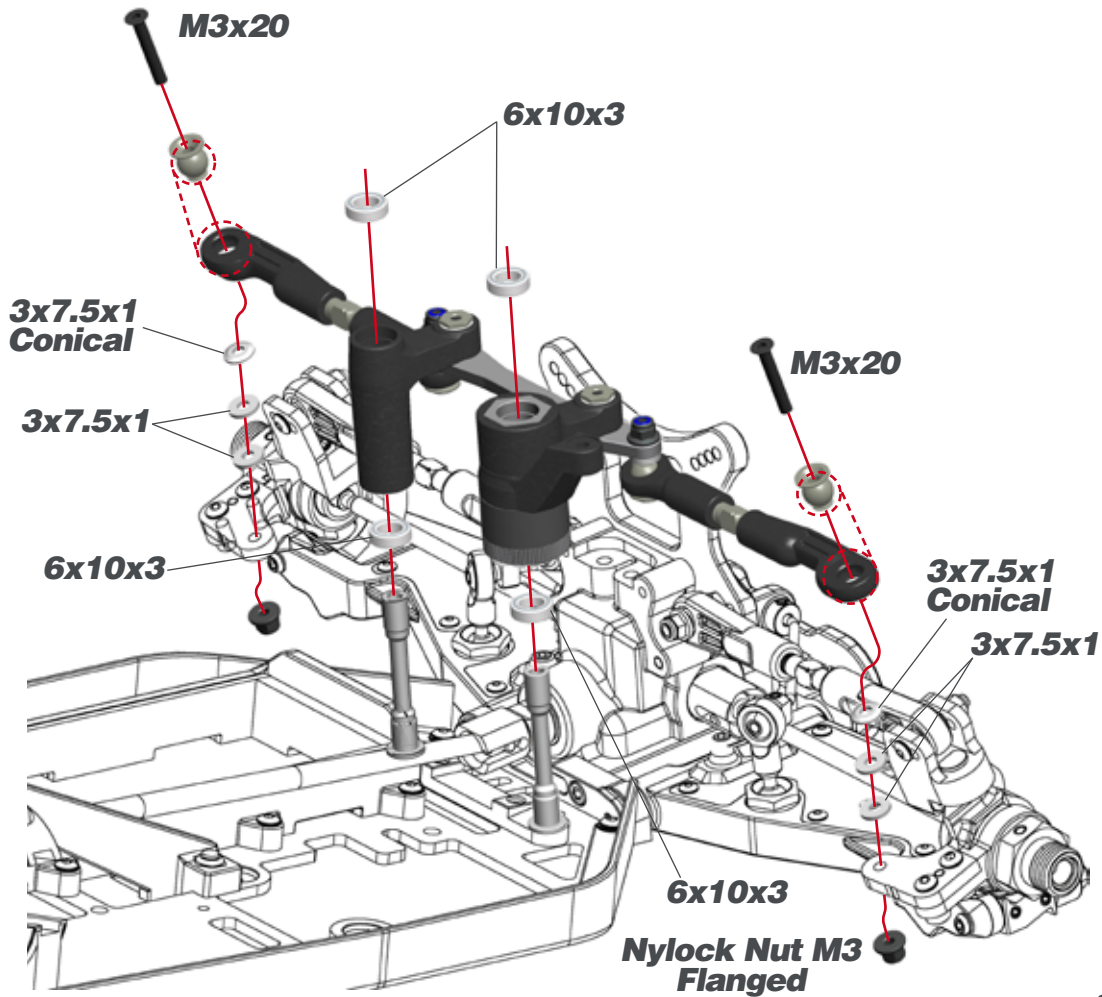

6x10x3

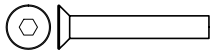

M3x20



3x7.5x1 Conical



3x7.5x1



Nylock Nut M3 Flanged

STEP 38

BAG 11

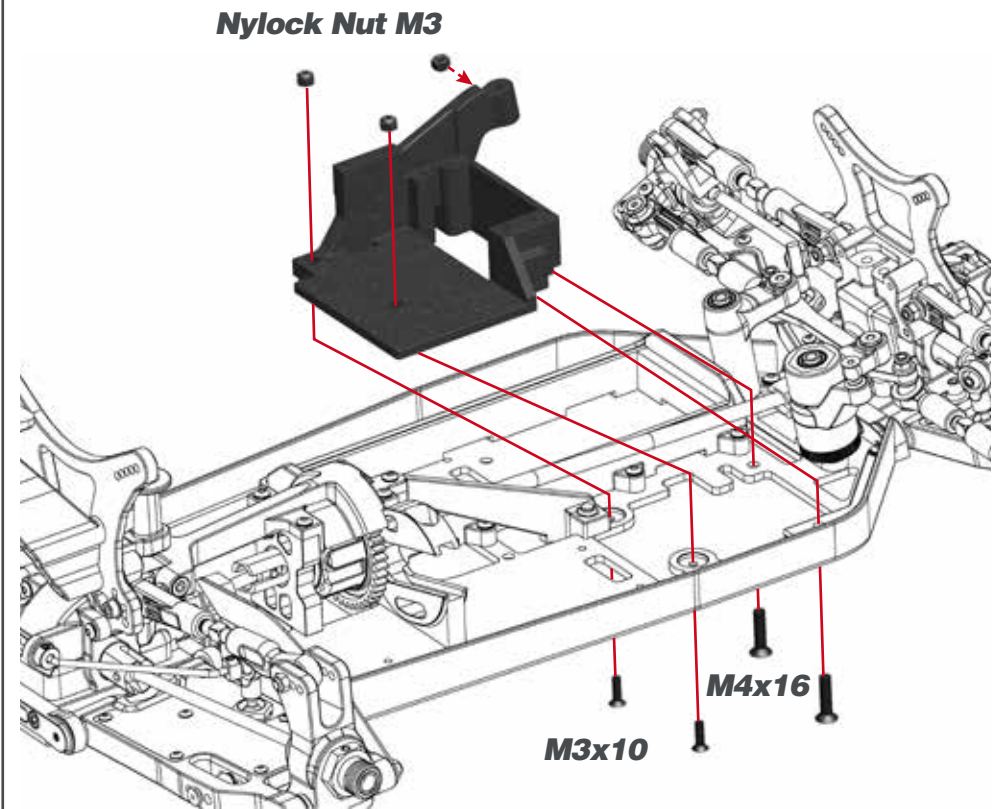

M3x10

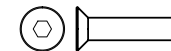

M3x14



Nylock Nut M3

M4x16

M3x10

STEP 39

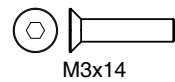
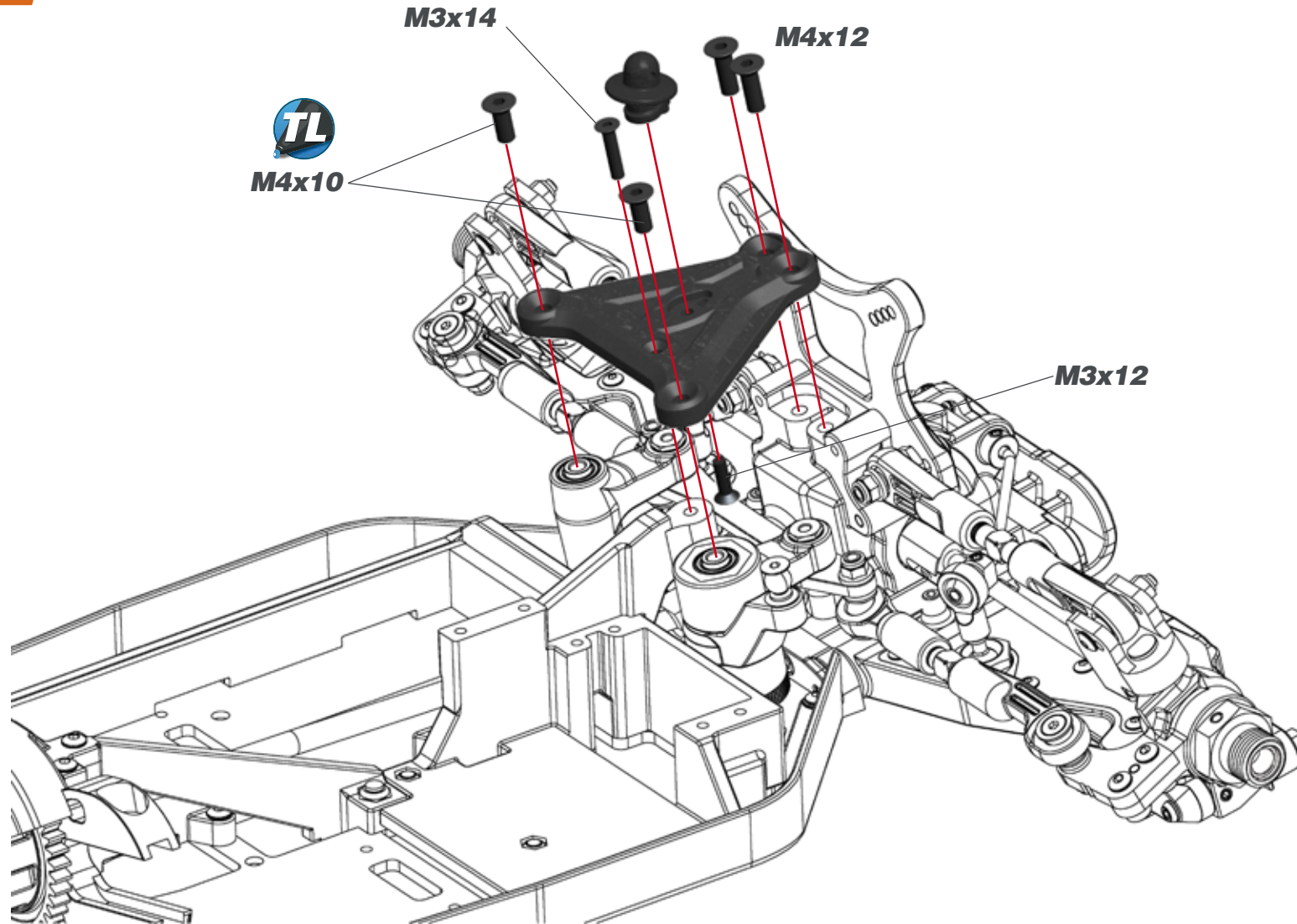

M3x14

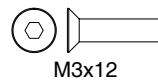

M3x12



M4x10



M4x12

STEP 40

40.1

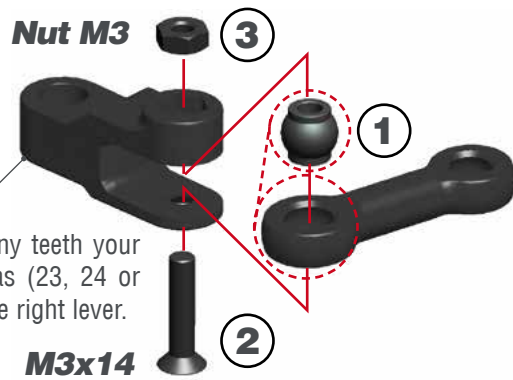

! Check how many teeth your servo spline has (23, 24 or 25) and use the right lever.

40.2



40.3

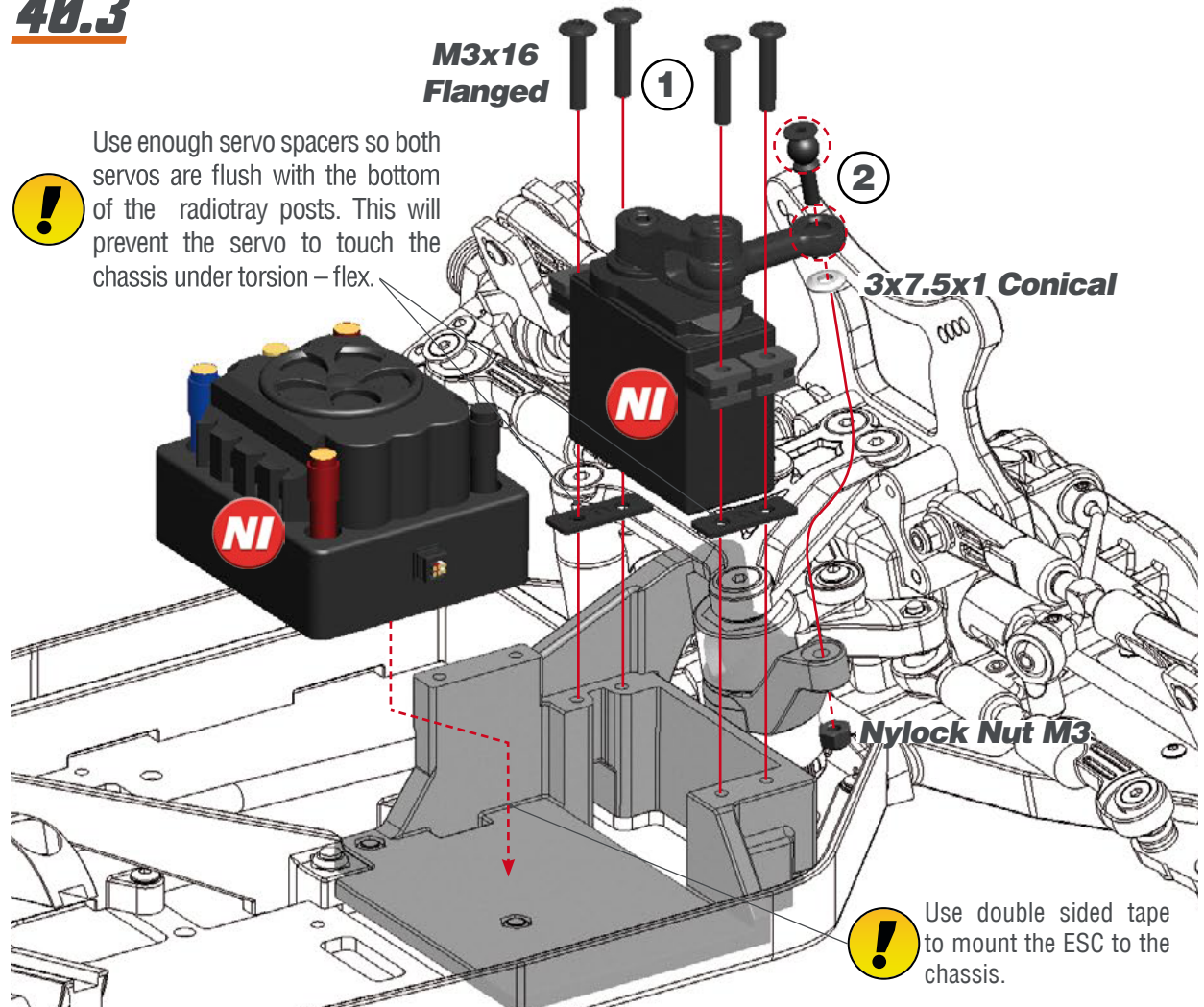

! Use enough servo spacers so both servos are flush with the bottom of the radiotray posts. This will prevent the servo to touch the chassis under torsion – flex.

! Use double sided tape to mount the ESC to the chassis.

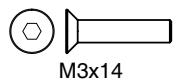

M3x14



Nut M3



M3x8



M3x16 Flanged



3x7.5x1 Conical



Nylock Nut M3

STEP 41

BAG 12

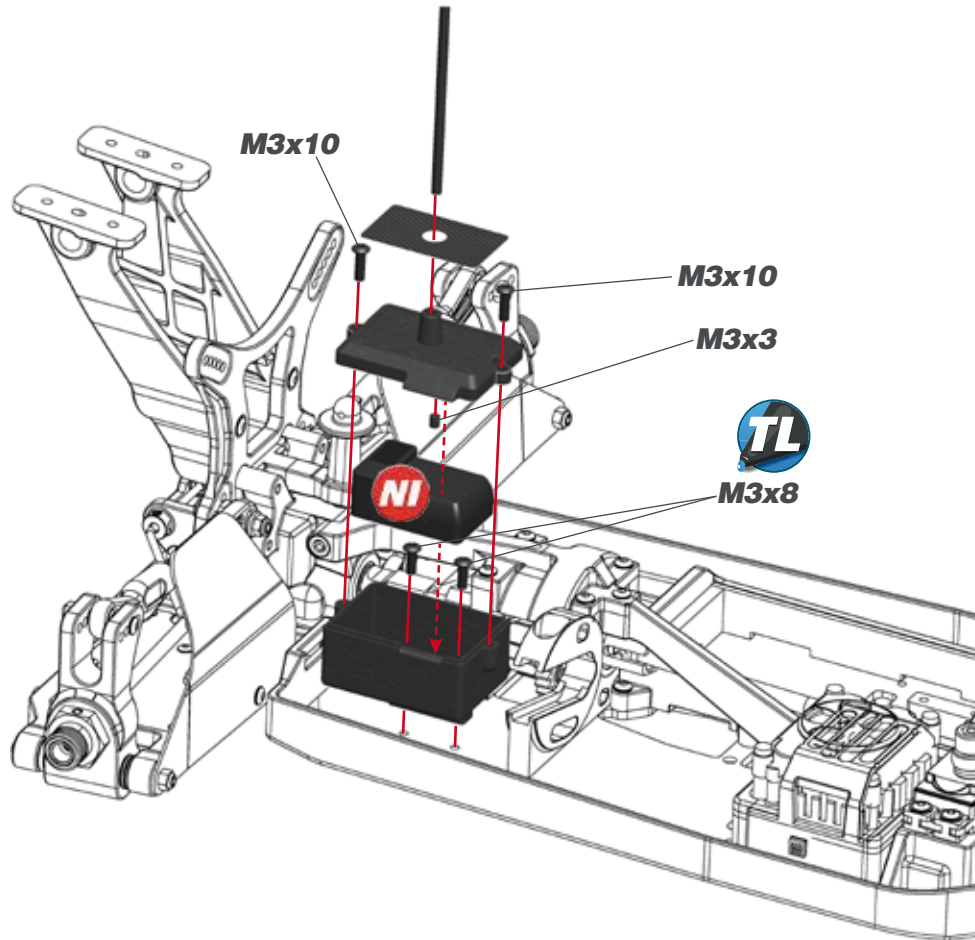

M3x3

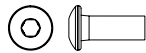

M3x8

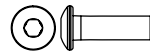

M3x10

STEP 42

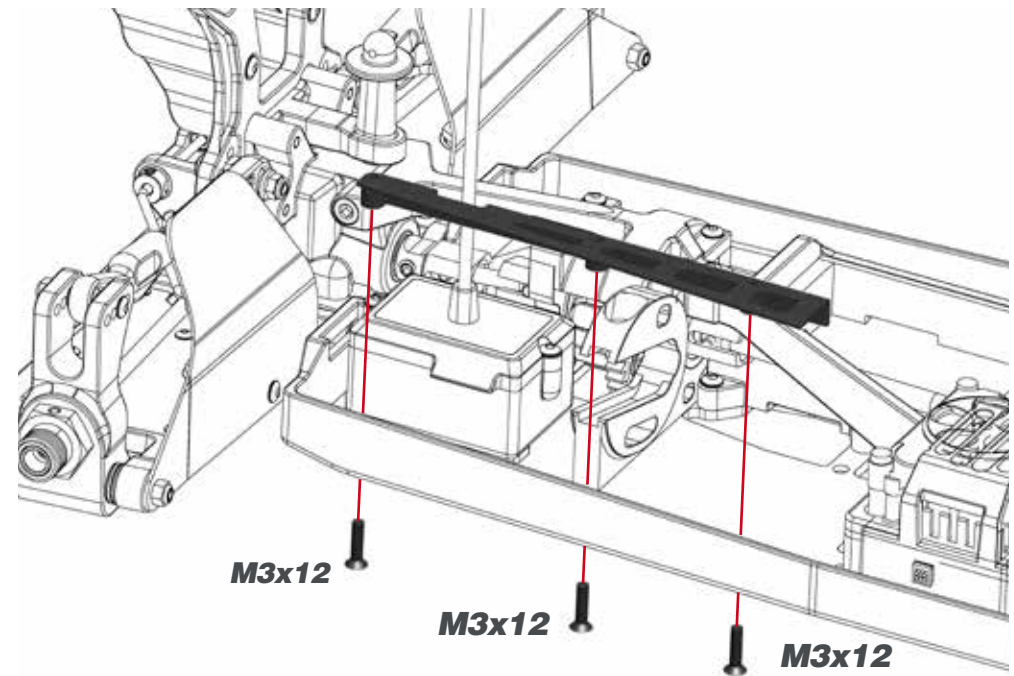

M3x12

M3x12

M3x12

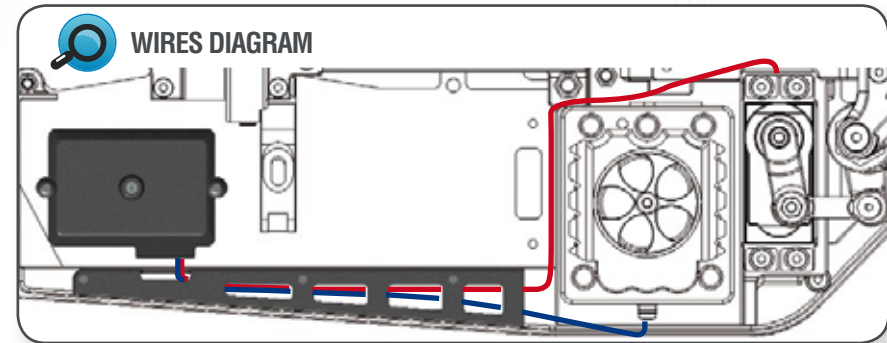

WIRES DIAGRAM



M3x12

STEP 43

43.1

NI  Pinion is not included in the kit. Assemble the proper pinion for your set-up.

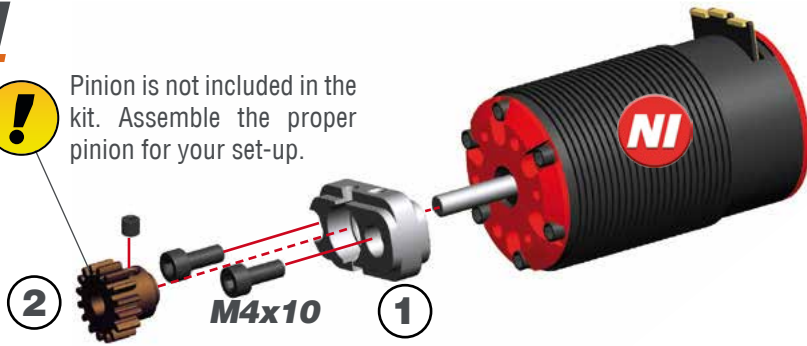

43.2

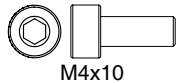
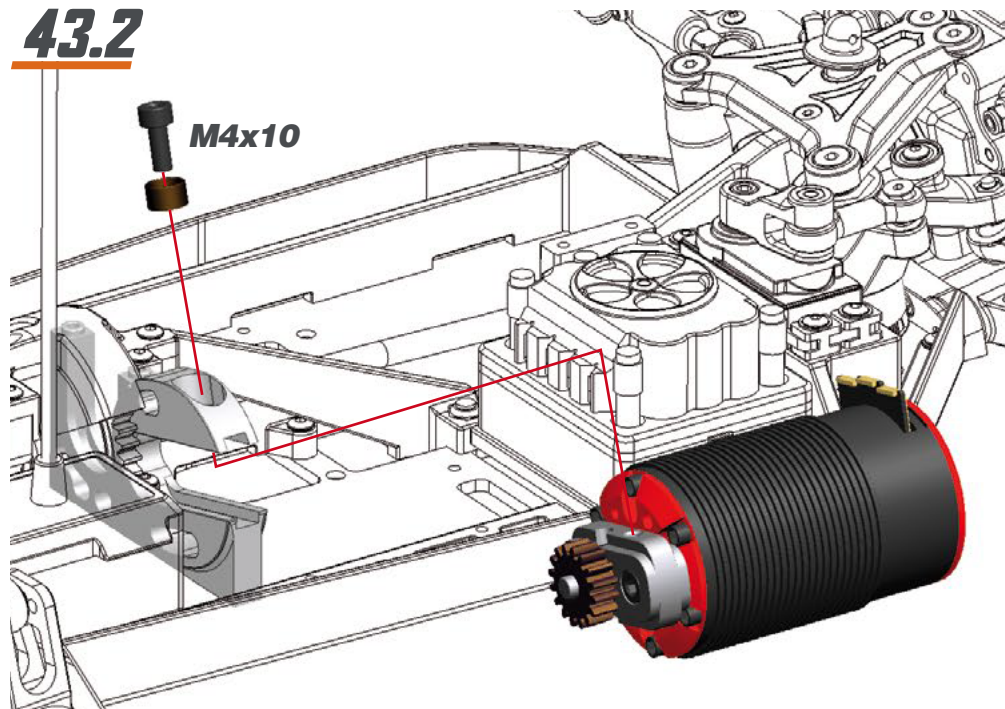

STEP 44

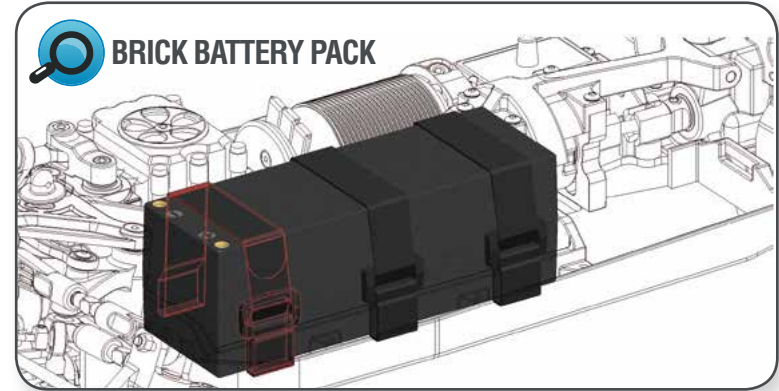
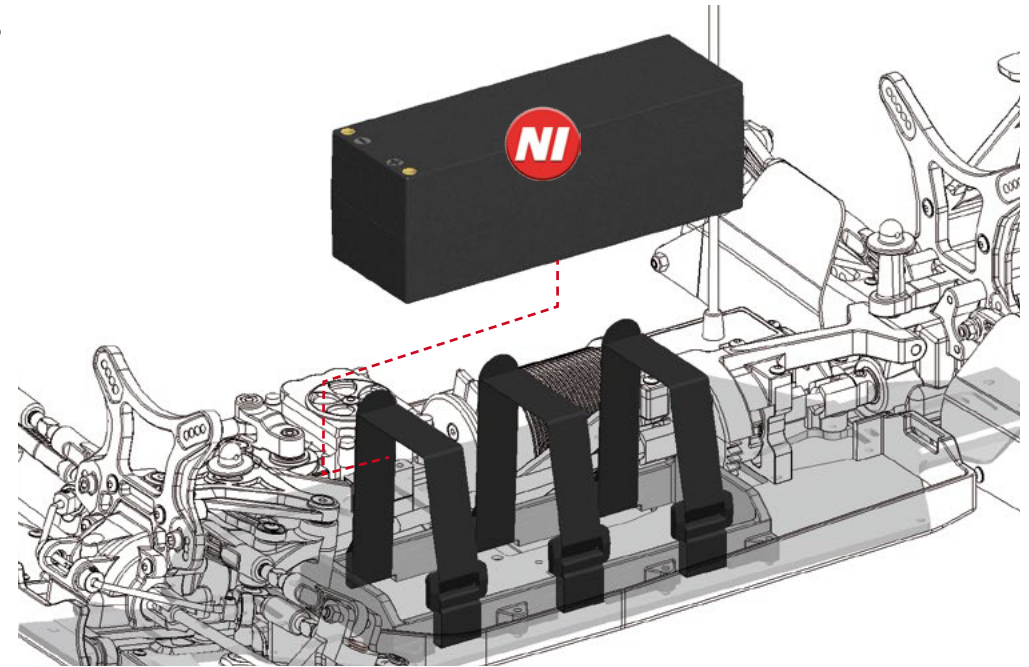

STEP 45 BAG 13 FR SHOCKS / BAG 14 RR SHOCKS

STEP 46

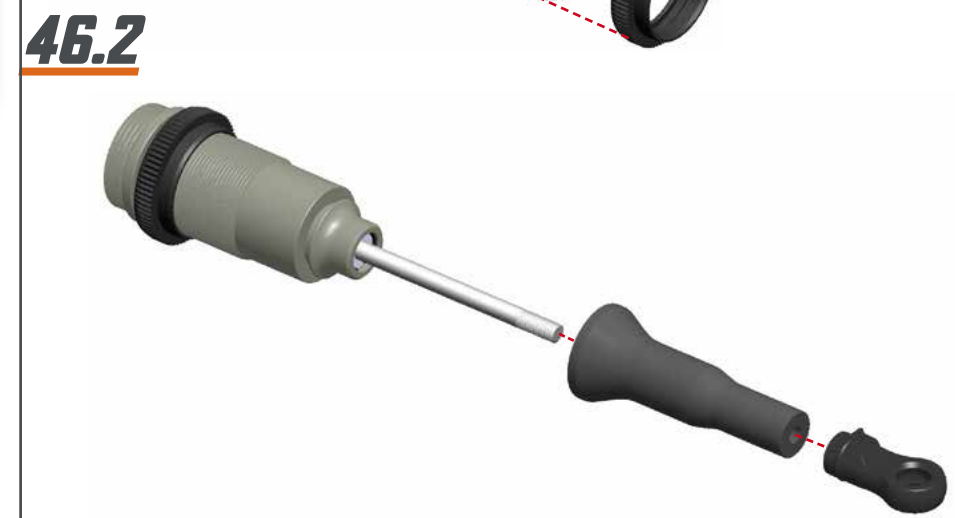
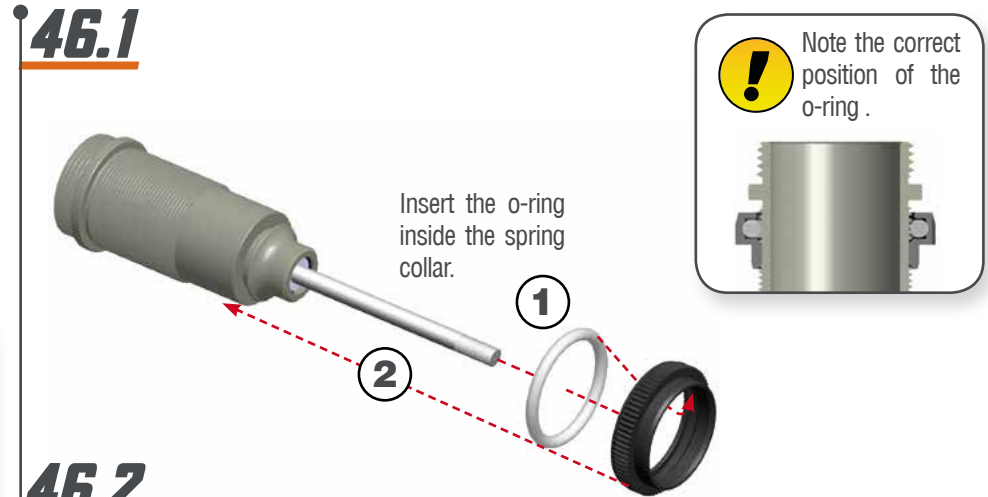
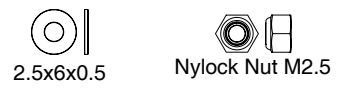
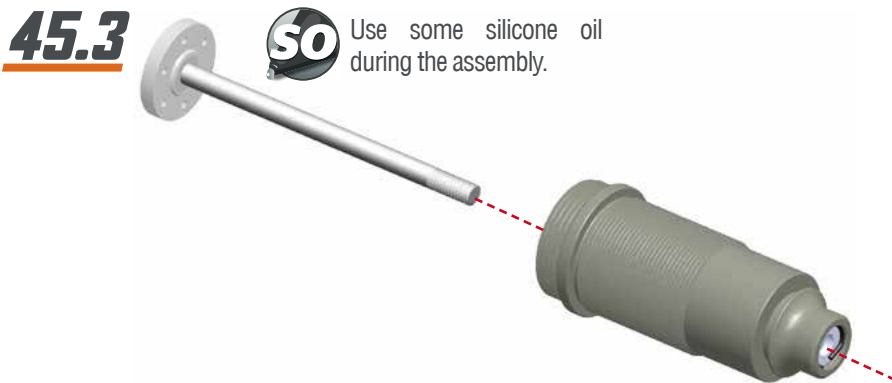
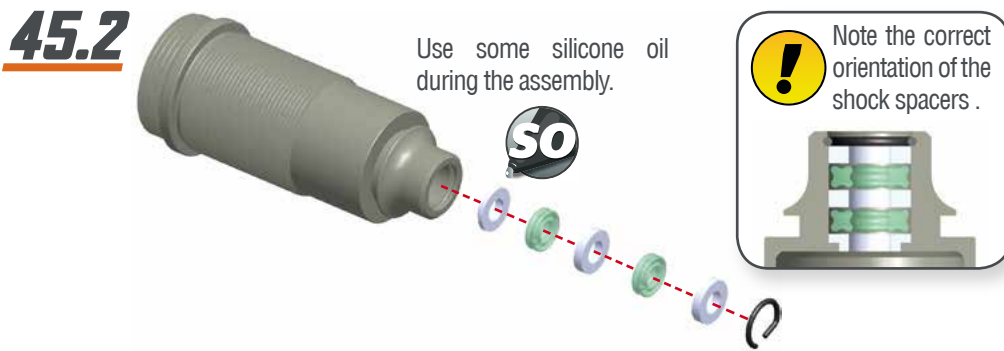
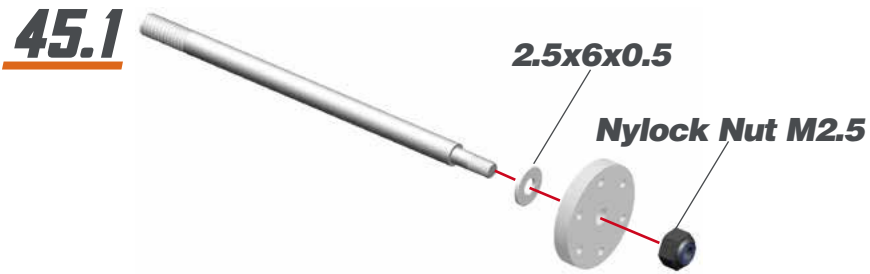

STEP 47

47.1

Push the membrane into the shock cap.



47.2

1- Fill up with silicone oil fully using the silicone oil supplied in the kit. For the correct cst value please check the default setupsheet.



2- Extend the shockrod fully

3- Move the shockrod slowly up and down to let ALL air bubbles escape.

4- Apply the gasket and cap and close fully.

47.3

1-Bleed: push the shock-rod all the way in slowly, to allow excessive oil to escape.

2- With shockrod fully in, mount the o-ring and screw.

M2.3x4



SHOCKS LENGTH: Measure the shock length fully extended.

FRONT

REAR

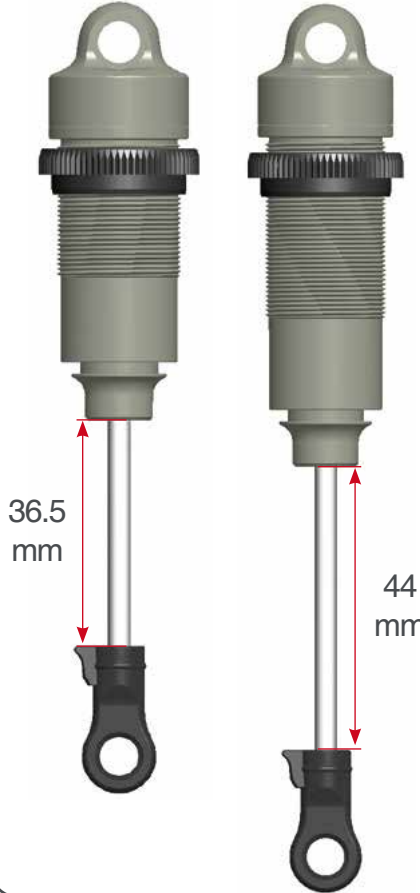

STEP 48

Assemble the spring and spring-cup (align correctly) to complete the shock.



M2.3x4

STEP 49 BAG 15

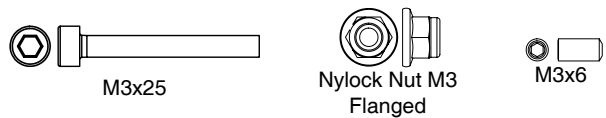
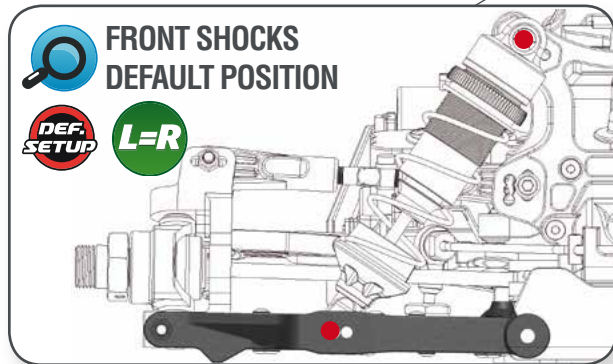
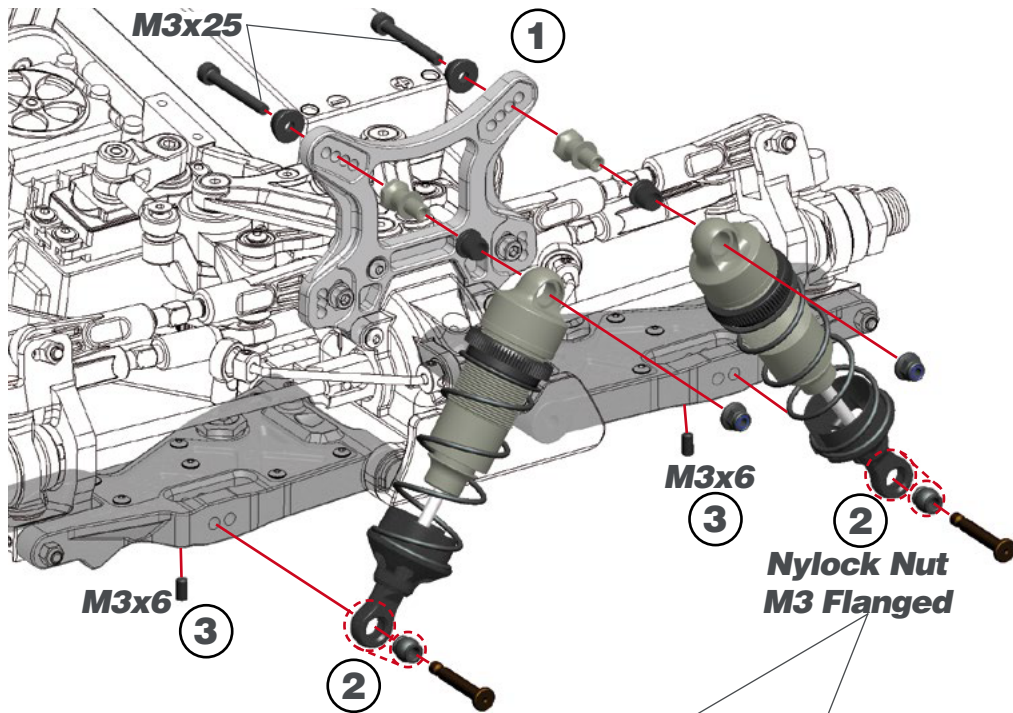

STEP 50

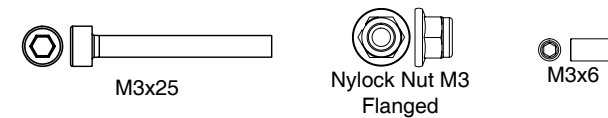
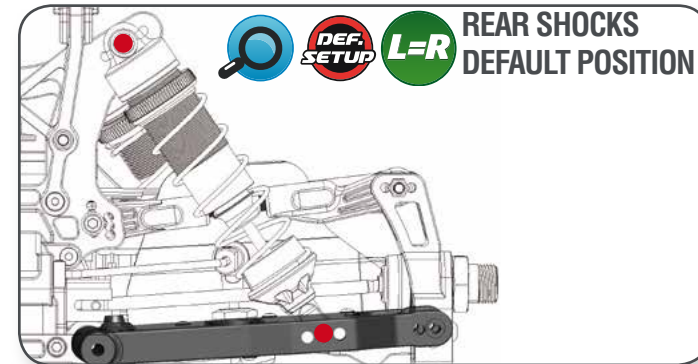
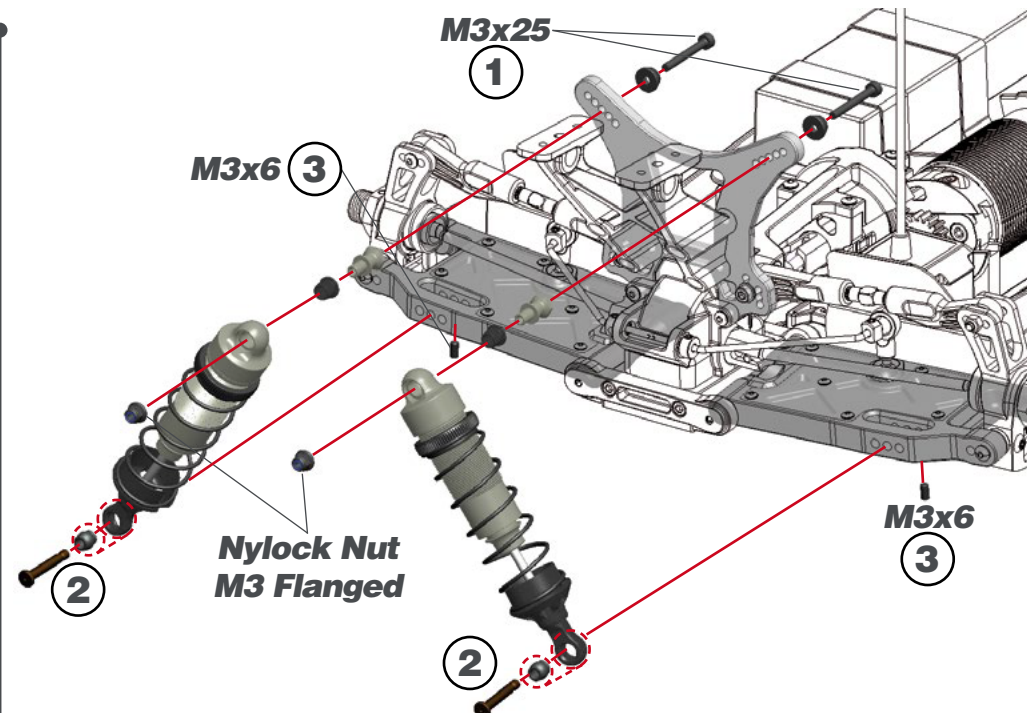

STEP 51

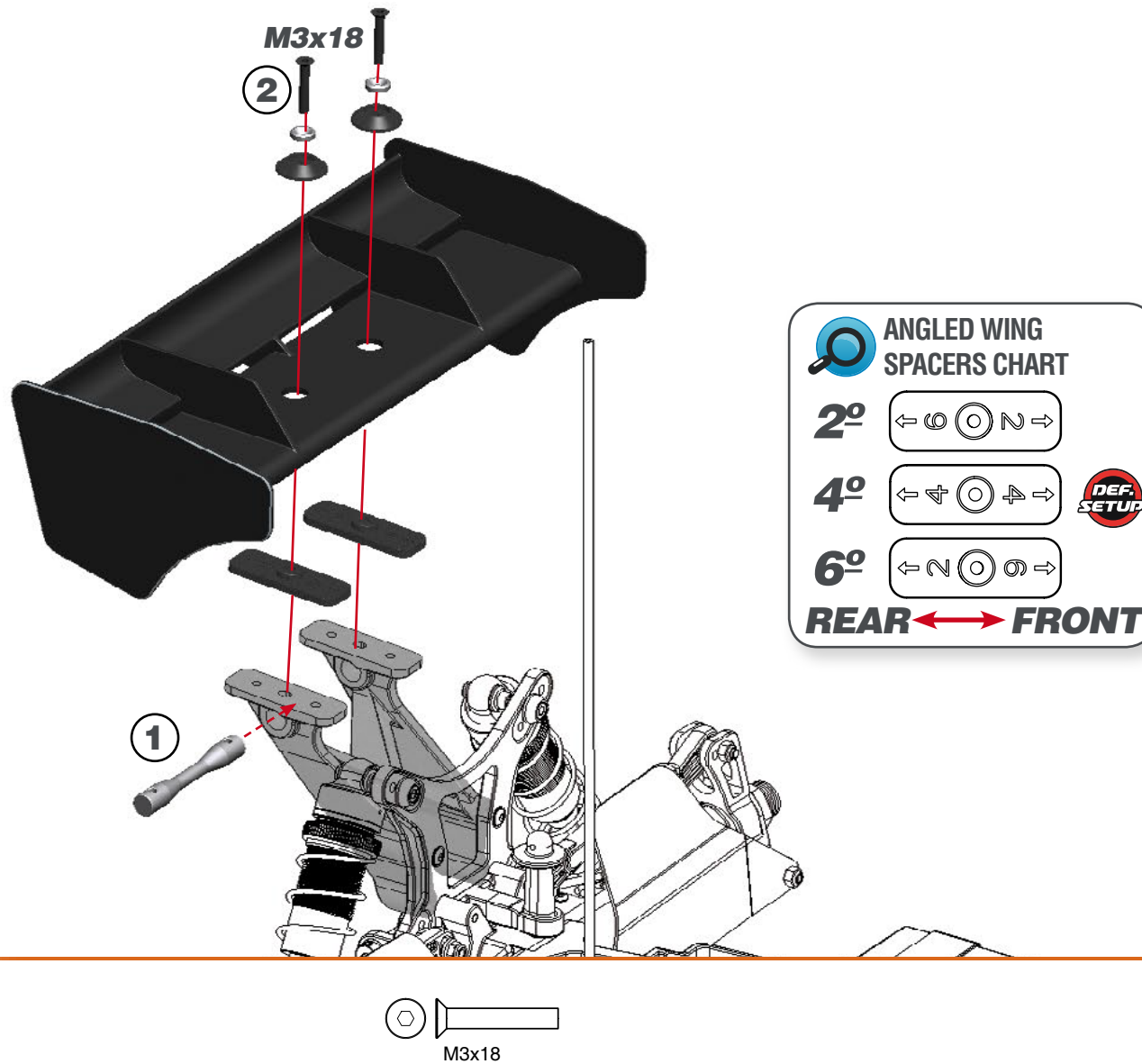

STEP 52

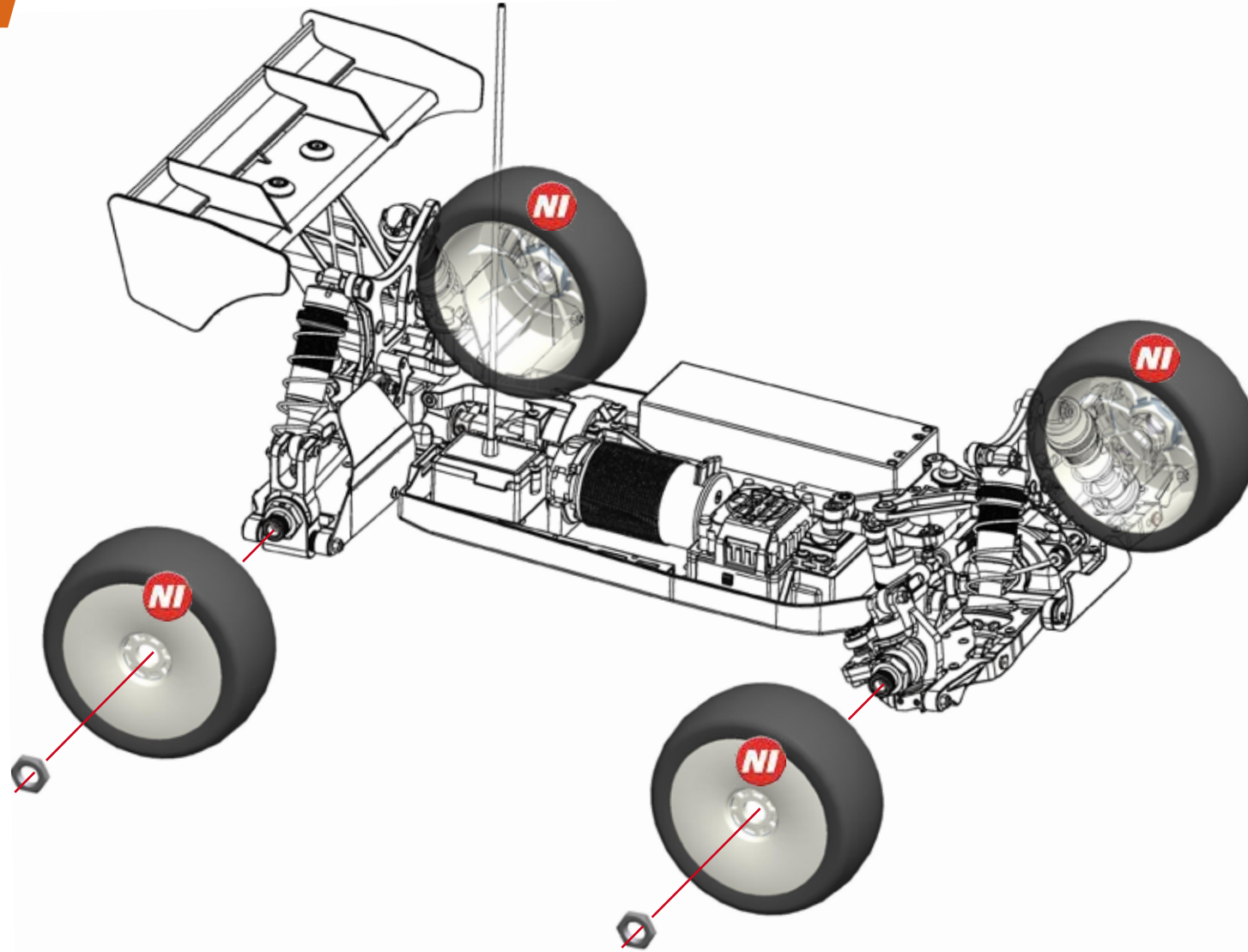

INDEX

<i>DIFFERENTIALS EXPLODED VIEW</i>	<i>37</i>
<i>REAR EXPLODED VIEW</i>	<i>38</i>
<i>FRONT EXPLODED VIEW</i>	<i>39</i>
<i>ASSEMBLY INSTRUCTIONS</i>	<i>40</i>
<i>STEERING EXPLODED VIEW</i>	<i>41</i>
<i>SHOCKS EXPLODED VIEW</i>	<i>42</i>
<i>FINAL 1 EXPLODED VIEW</i>	<i>43</i>
<i>FINAL 2 EXPLODED VIEW</i>	<i>44</i>

FRONT EXPLODED VIEW

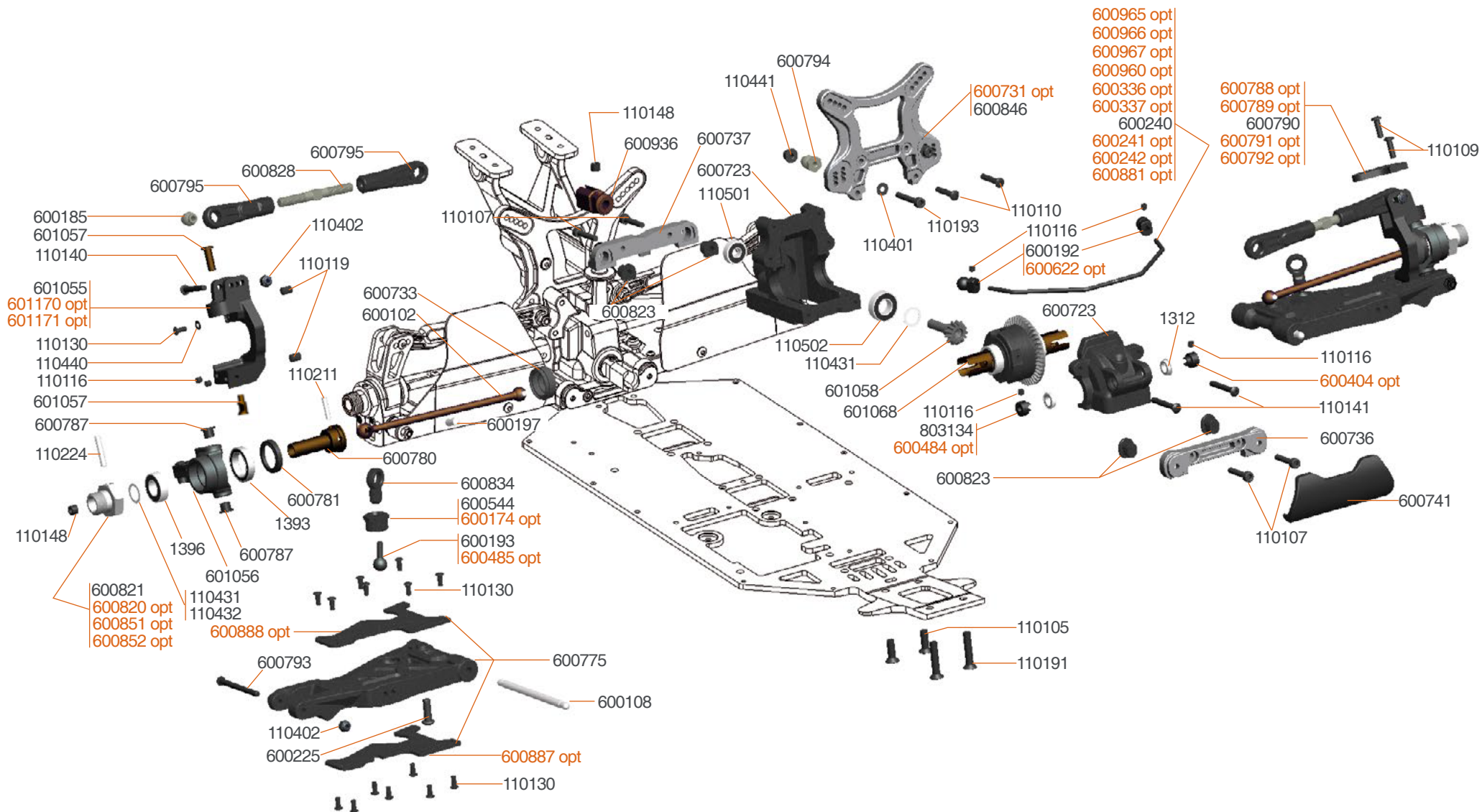

- 600336 Antiroll bar front 1.8mm
- 600337 Antiroll bar front 2.0mm
- 600241 Antiroll bar front 2.5mm
- 600242 Antiroll bar front 2.7mm
- 600881 Antiroll bar front 3.0 mm
- 600484 Antirollbar spacer 3mm alu (2)
- 600485 Pivotball threaded anti roll bar alu (2)

- 601170 C-hub 15deg KPI L+R alu SRX8
- 601171 C-hub 19deg KPI L+R alu SRX8
- 600174 Antirollbar nut (2)
- 600788 Steering arm 0 carbon (2) SRX8
- 600789 Steering arm 1 carbon (2) SRX8
- 600791 Steering arm 3 carbon (2) SRX8
- 600792 Steering arm 4 carbon (2) SRX8

- 600820 Wheelhexagon 0mm (2) SRX8
- 600846 Shocktower FR alu SRX8
- 600851 Wheelhexagon 0mm light (2) SRX8
- 600965 Antiroll bar front 2.2 mm
- 600966 Antiroll bar front 2.4 mm
- 600967 Antiroll bar front 2.6 mm
- 600622 Pivotball antirollbar alu (4)

- 600852 Wheelhexagon +1mm light (2) SRX8
- 600887 Wishbone insert carbon FR Lower SRX8 (2)
- 600888 Wishbone insert carbon FR Upper SRX8 (2)

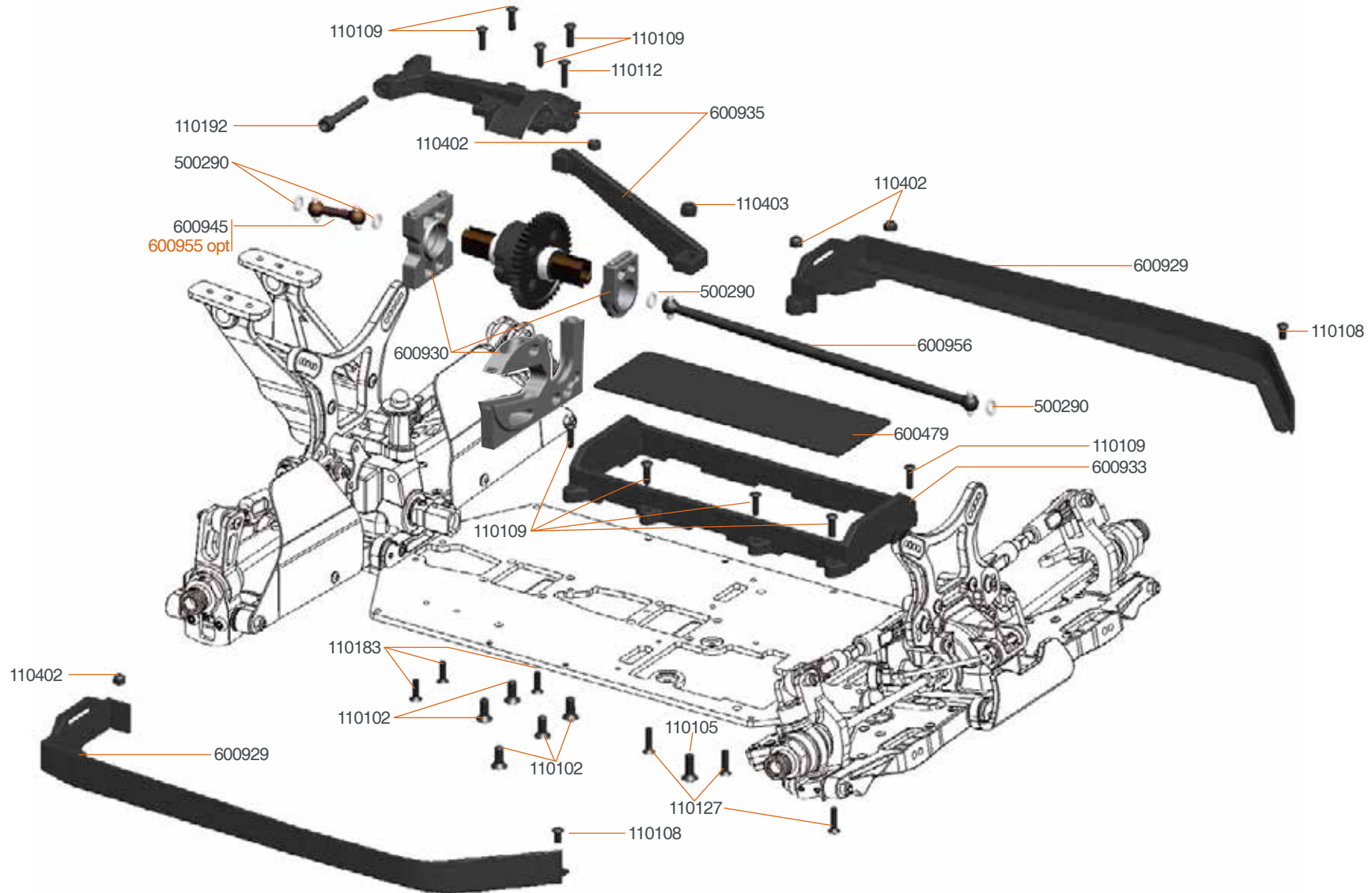

OPT 600955 Driveshaft center rr alu block layout SRX8E
600959 Saddle pack layout set SRX8E

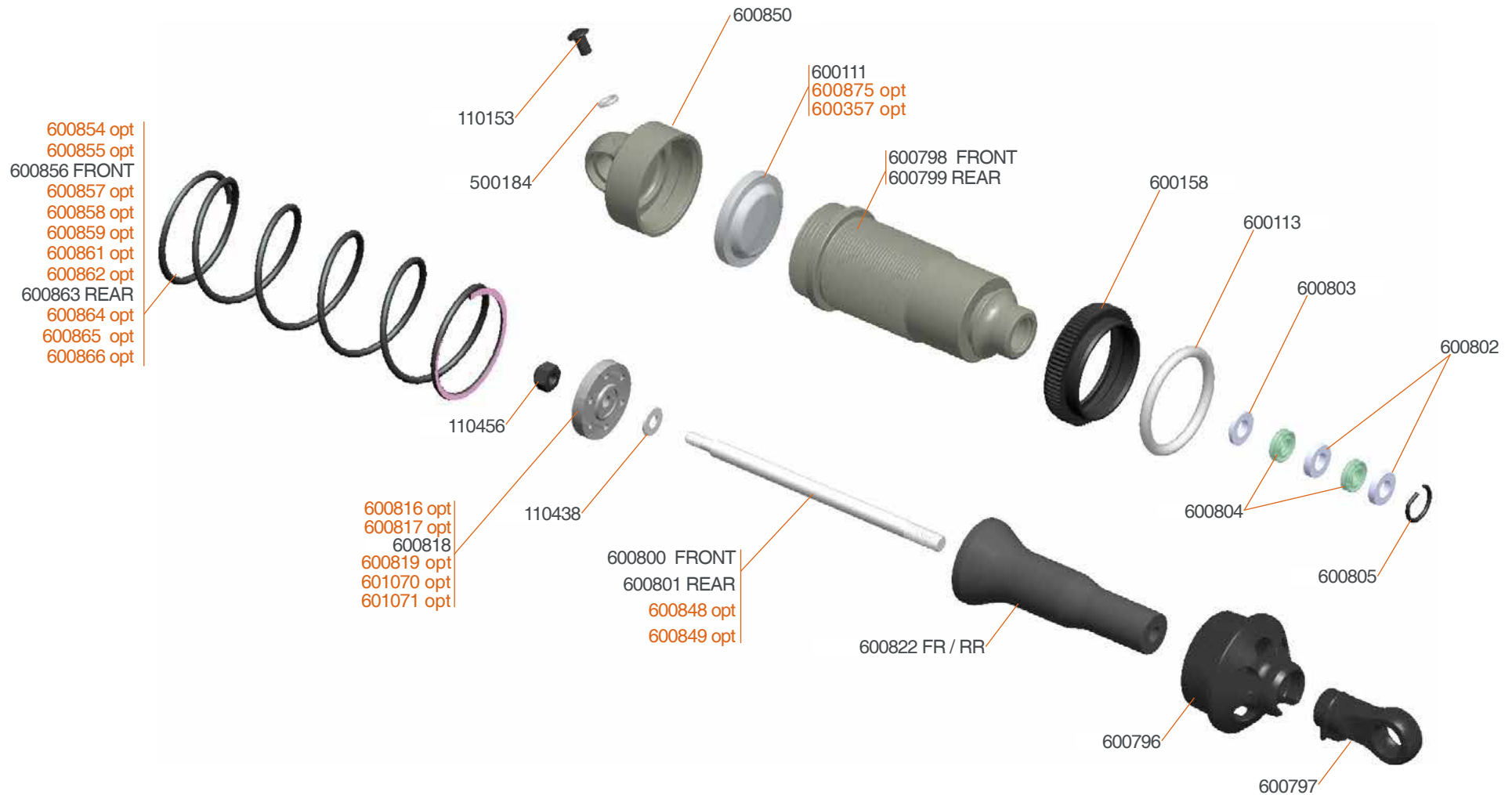

600854 Shockspring FR 4.5 lbs orange (2)	600861 Shockspring RR 3.0 lbs orange (2)	600357 Membrane webbed silicone (4)	600870 Shock set Pro front (2) SRX8
600855 Shockspring FR 4.7 lbs red (2)	600862 Shockspring RR 3.2 lbs red (2)	600816 Shock piston blank (4) SRX8	600871 Shock set Pro rear (2) SRX8
600857 Shockspring FR 5.1 lbs blue (2)	600864 Shockspring RR blue 3.6lbs (2)	600817 Shock piston 5 holes (4) SRX8	600875 Shock top gasket (4) SRX8
600858 Shockspring FR 5.3 lbs purple (2)	600865 Shockspring RR 3.8 lbs purple (2)	600819 Shock piston 8 holes (4) SRX8	601070 Shock piston angled 1.2mm 8holes (4) SRX8
600859 Shockspring FR 5.5 lbs green (2)	600866 Shockspring RR 4.0 lbs green (2)	600848 Shock shaft FR TiN coated (2) SRX8	601071 Shock piston angled 1.3mm 8holes (4) SRX8
600860 Shockspring set FR (6x2)	600867 Shockspring set RR (6x2)	600849 Shock shaft RR TiN coated (2) SRX8	



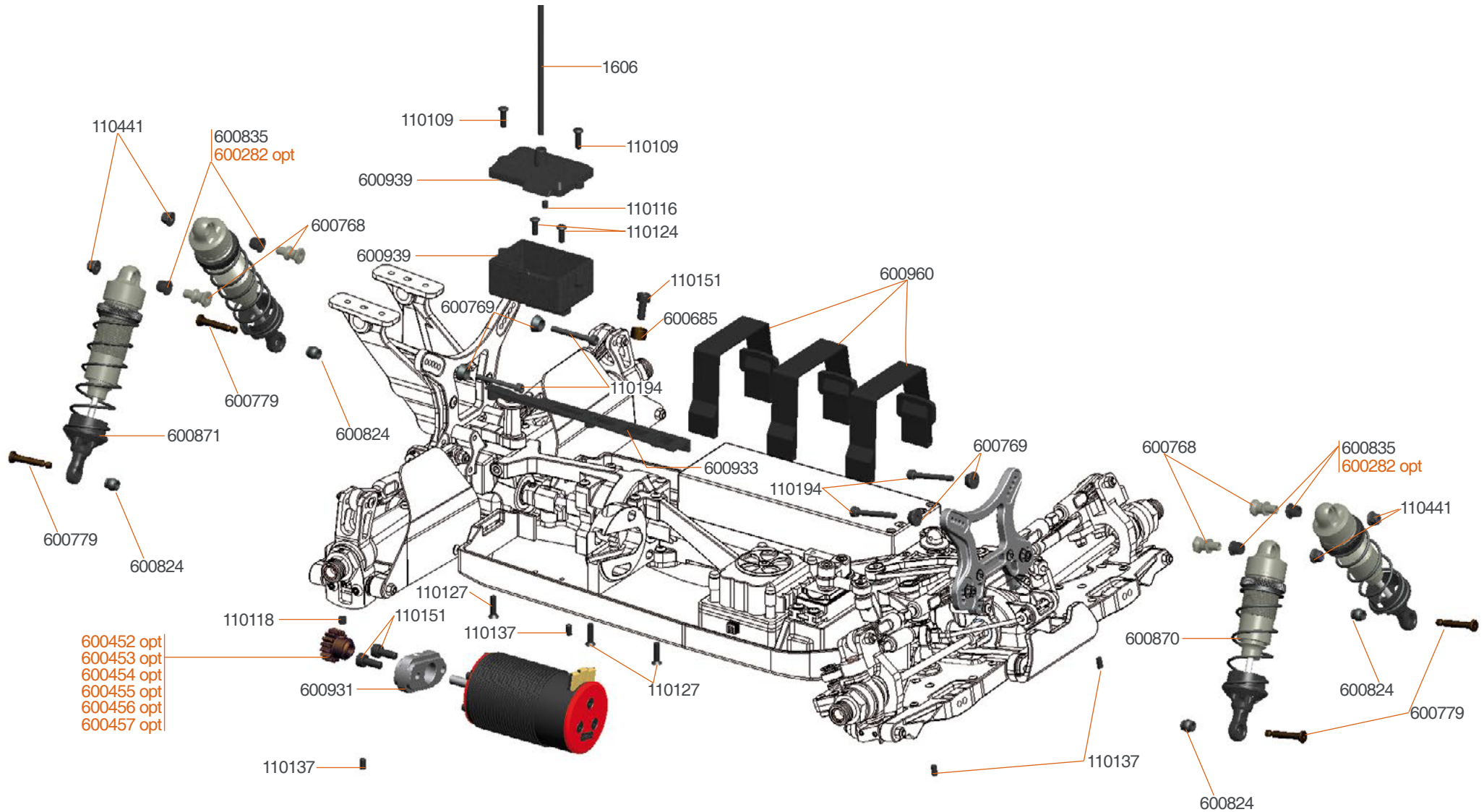

600282 Shock-pivot bushing delrin (4)
600452 Pinion 12T
600453 Pinion 13T

600454 Pinion 14T
600455 Pinion 15T
600456 Pinion 16T

600457 Pinion 17T
600870 Shock set Pro front (2) SRX8
600871 Shock set Pro rear (2) SRX8

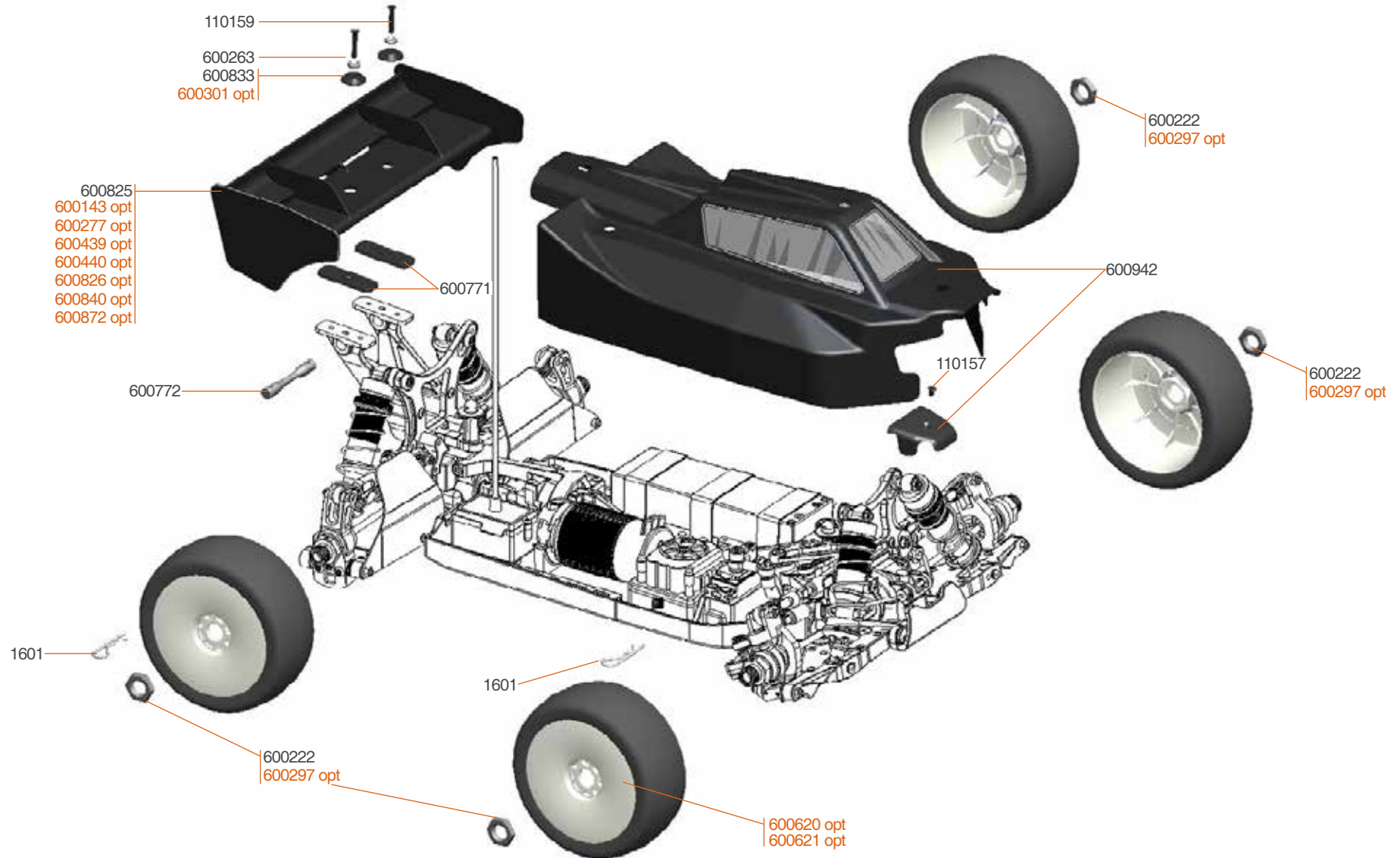

600297 Wheel-nut17mm flanged/light (4)
600143 Wing white nylon
600277 Wing black nylon

600439 Wing white low 811
600440 Wing black low 811
600826 Wing straight MD white 1/8

600840 Wing lexan HD with gurney 1/8
600872 Wing gurney
600620 Rim 1/8 buggy White (4)

600621 Rim 1/8 buggy Yellow (4)

TEAM SERPENT NETWORK

SRX8-E PRO SPARE PARTS www.serpent.com/833221/spares/



SRX8-E PRO OPTIONALS PARTS www.serpent.com/833221/Optionals/



SERPENT TOOLS www.serpent.com/product/Tools/



SERPENT MERCHANDISING www.serpent.com/product/Merchandising/



SERPENT WEBSITE AND BLOG

www.serpent.com
www.teamserpent.com
www.dragon-rc.com

SERPENT PROMO PAGES <http://promo.serpent.com>

SERPENT FACEBOOK GROUPS <http://promo.serpent.com/indexfb.htm>

SERPENT ADVANCED MANUALS <http://promo.serpent.com/sam/>

SERPENT SOCIAL MEDIA



www.facebook.com/SerpentMRC



www.youtube.com/user/SerpentMRC



www.twitter.com/SerpentMRC



www.plus.google.com/+SerpentModelcars/posts



www.weibo.com/teamserpent

INSTRUCTION MANUAL

PRO
COBRA
SRX8E



Manual SRX8-E PRO #832211

SERPENT