

K5 Blazer



TRX4

HIGH TRAIL™
EDITION

TRAXXAS NEW PRODUCT SALES TRAINING

TRAXXAS®

K5 Blazer

HIGH TRAIL ADVENTURE

Traxxas High Trail Edition™ TRX-4® models are the biggest and baddest trucks on the trail, and now classic Blazer fans have reason to celebrate. The 1972 Chevrolet® K5 Blazer gets the full High Trail treatment with a big, lifted stance and beautifully detailed body. The factory-installed Long Arm Lift Kit boosts the Blazer's ground clearance by more than an inch with larger 2.2" wheels and tires to conquer the roughest terrain. K5 Blazer High Trail Edition delivers more of what you crave—extreme all-terrain capability, stunning scale looks, and Traxxas-Tough™ durability.

NEW
CHEVROLET K5 BLAZER

CHEVROLET K10



CUSTOMER TARGET DEMOGRAPHICS

TRX-4 Owners

All the scale realism of a custom rig with a massive lift, and bigger tires built Ready-to-Drive® by Traxxas.

Mud Truck Fans

Exploring muddy trails is no problem with the higher ground clearance and patented waterproof electronics.

Chevrolet Enthusiasts

Fans of the "Bow Tie" will naturally want to own a lifted 4WD Chevy K5 Blazer with classic style.

LINEUP & PRODUCT POSITION



TRX-4 Sport

A lighter, performance driven approach to outdoor adventure.



TRX-4 Bronco

Rugged off-road performance with an officially-licensed clipless body.



TRX-4 F-150

A beautifully detailed Ford® F-150® body with extended chassis and high-performance lift kit.



TRX-4 K5

The latest High Trail Edition TRX-4 loads Chevy fans up with extreme capability and bright chrome details.



TRX-4 K10

Extreme all-terrain capability with lifted chassis, 2.2" wheels, and highly detailed clipless body.



DISPLAY IT IN YOUR STORE

Remove your TRX-4 High Trail Edition K5 Blazer from the box and display it prominently in your store. Encourage customers to try out the simplicity of Traxxas' clipless body technology and appreciate the smooth flowing lines of the stunning replica K5 Blazer body. Your customers will see the performance benefits that come from the factory-installed Long Arm Lift Kit and oversize 2.2" chrome wheels and tires.

STANDARD K5 BLAZER**OVER 1 INCH
ADDITIONAL GROUND
CLEARANCE**

EXCEPTIONAL VALUE

TRX-4 High Trail Edition trucks represent an exceptional value to your customers with \$275 in optional accessories.

- Factory Long Arm Lift Kit - \$175 Value
- 2.2" Canyon Trail Tires and 8-Hole Chrome Mag Wheels with Center Caps - \$100 Value

FEATURES

- Factory-Installed Long Arm Lift Kit
- Clipless K5 Blazer Replica Body
- Deep-Inset Chrome Grille with Light Buckets
- 2.2" Chrome 8-Hole Mag Wheels
- S1-Compound Canyon Trail Tires
- TQi™ 2.4GHz Radio System with Cruise Control
- 3s Power System
- Waterproof Electronics
- High/Low Range Transmission
- T-Lock™ Remote Locking Differentials
- Portal Axles
- Heavy-Duty Steel Frame Rails
- High-Torque Metal Gear Servo
- Aluminum GTS Oil-Filled 110mm Shocks

K/5 Blazer

Molded Trim with Woodgrain Insert

Trailer Hitch Receiver

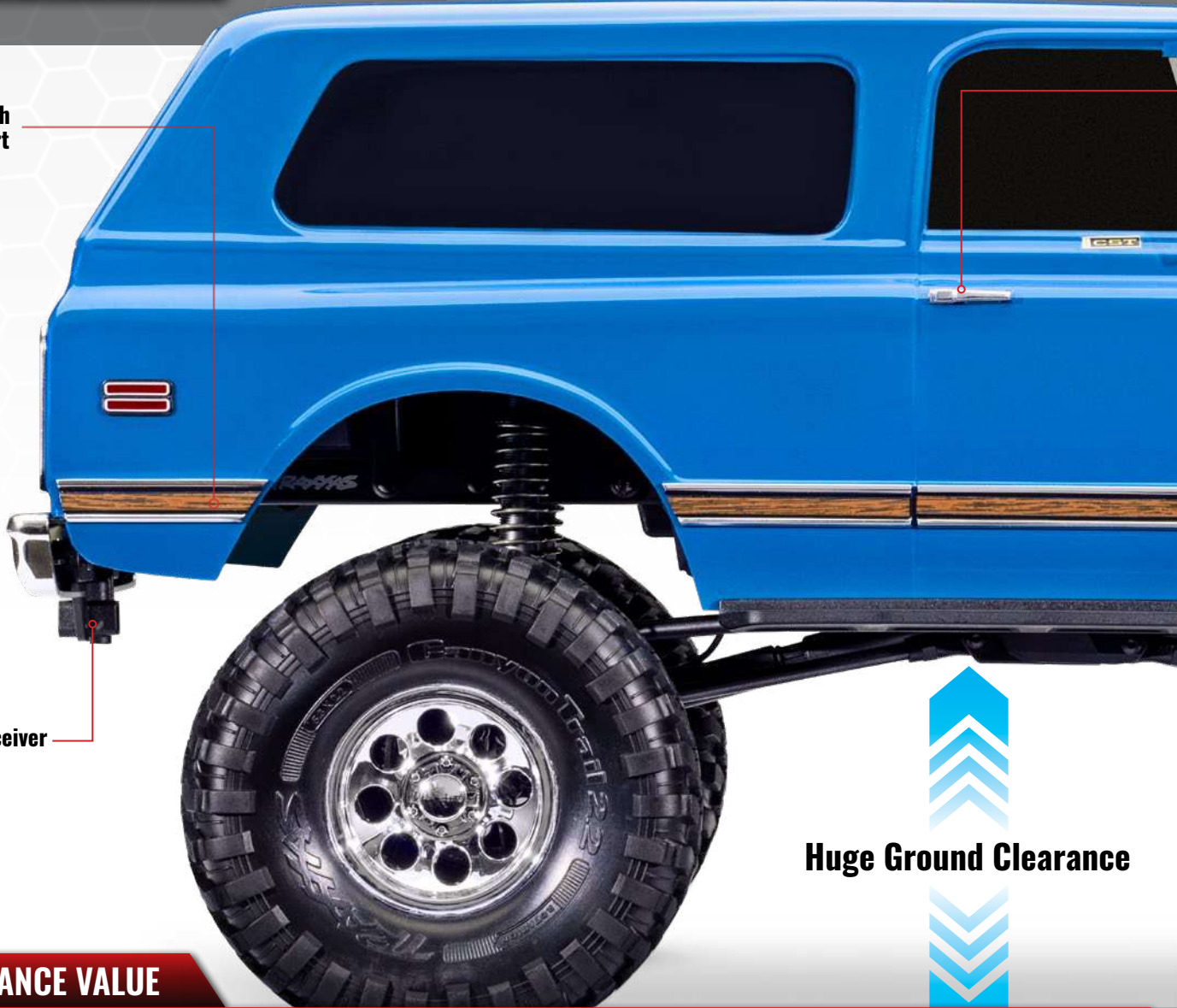

Huge Ground Clearance

PERFORMANCE VALUE



Long Arm Lift Kit

Adds over an inch of trail-conquering ground clearance



Extended-Length 110mm GTS Shocks

Threaded aluminum bodies for easy ride height adjustment



2.2' Wheels & Tires

8-hole chrome mag wheels with hub inserts and 2.2" Canyon Trail tires



Chrome Scale Details

LED-Ready Headlight, Side Marker, and Tail Light Assemblies

ADD-ON SALES OPPORTUNITIES

Pro Scale® Winch

Install an accessory Pro Scale Winch (#8855). Requires winch-compatible bumper (#8869).



#8855

Traxxas Link™ Wireless Module

Add the Wireless Module (#6511) to use the inclinometer in the Traxxas Link app.



#6511

Pro Scale Lighting

Compatible with Pro Scale Lighting System (#8090X).



70° Approach Angle

Extreme climbing capability provided by a 70° out-of-the box approach angle



Clipless Body

Holds tight on the trail, but releases in seconds

New Accessory Clipless Bodies

Direct replacement bodies for the K5 High Trail Edition and easy conversion for older TRX-4 models.



#9130-BLUE

Blue Body, 1972 Blazer

#9130-RED

Red Body, 1972 Blazer

#9130

Clear Body, 1972 Blazer

New Clipless Conversion Parts

#8072X

Inner Fenders, Wide (F&R)

#9128

Body cage/ body mounts (F&R)

K/5 Blazer

Clipless Body Mounts

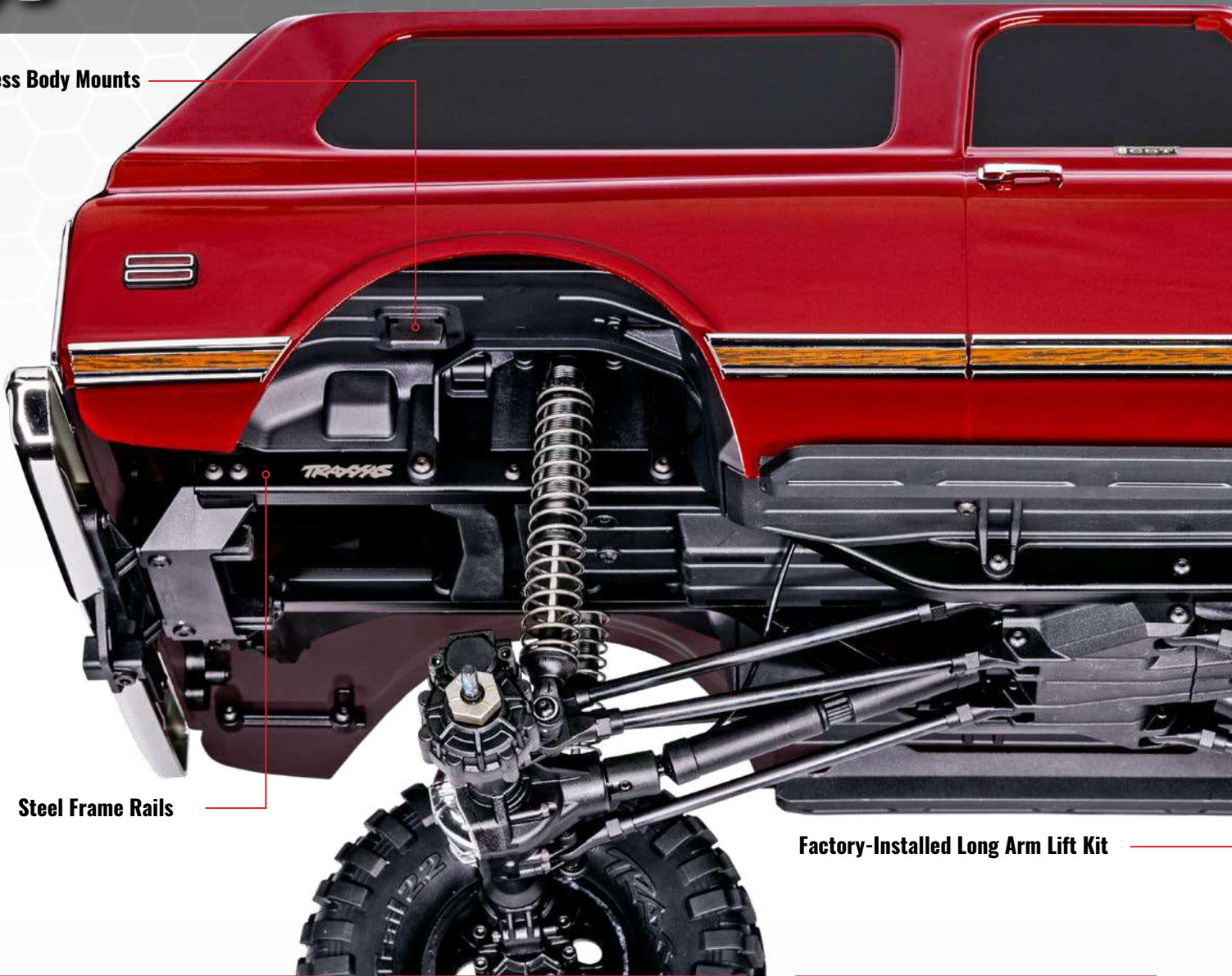

Steel Frame Rails

Factory-Installed Long Arm Lift Kit



High/Low Range Transmission

Torque when you need it,
speed when you want it



Remote Locking Differentials

Lock the differentials on the fly for
unstoppable traction

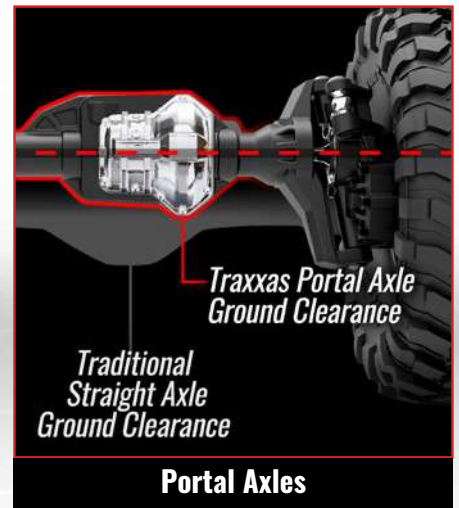

Portal Axles

More ground clearance, better geometry,
no torque twist



TECHNICAL RESOURCES

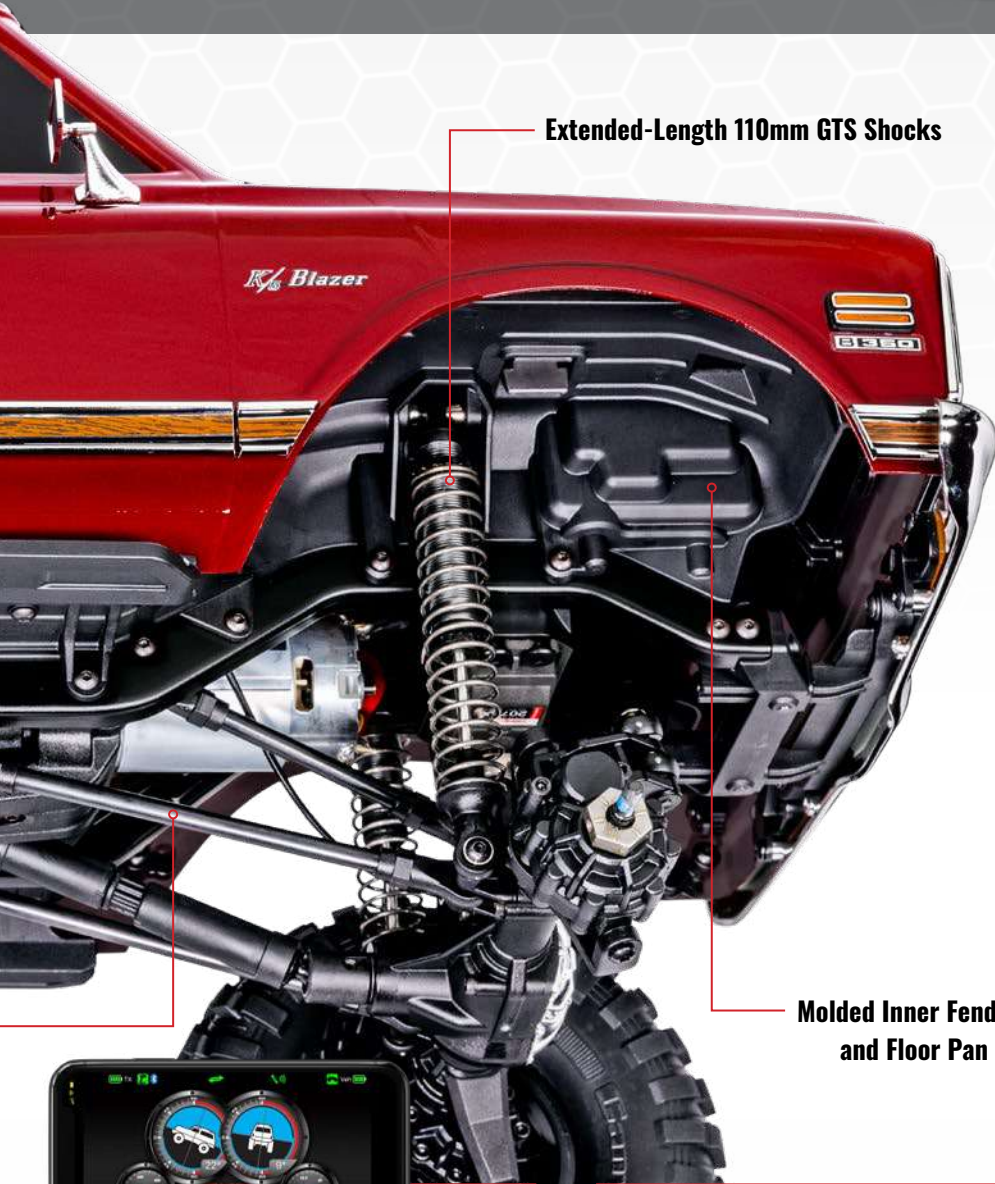

Extended-Length 110mm GTS Shocks

Molded Inner Fenders and Floor Pan

Supreme Off-Road Capability

Go further than ever before with K5 Blazer's extra ground clearance and aggressive approach angles



Clipless Convenience

K5's clipless body mounts hold tight, but release in seconds without the need for clips and body posts



High-Torque Metal Gear Servo

The 2075X metal gear servo and steel servo horn provide ultimate durability and steering authority

Torque:

125 oz-in @ 6V



Steel Servo Horn

2.2" Chrome Mag Wheels



CANYON TRAIL 2.2" 5.3" DIAMETER

CANYON TRAIL 1.9" 4.6" DIAMETER



BLUETOOTH READY

Add the 6511 Wireless Module and use the inclinometer in the Traxxas Link app.



TQi™ 4-Channel Radio System

Features exclusive Cruise Control for long distance treks



3s Power System

Strong. Efficient. Waterproof. The XL-5 HV ESC and Titan® 21-Turn motor

K/5 Blazer



TRX4

HIGH TRAIL™
EDITION

TRAXXAS

FOR INTERNAL USE ONLY. DO NOT DISTRIBUTE.



OFFICIAL
LICENSED PRODUCT

© Copyright Traxxas 2023